

Statewide Space Standards

Version 1.1.9



The State of Missouri
Office of Administration
Division of Facility Management Design and Construction

© 2006

TABLE OF CONTENTS

| | |
|--|---------|
| Publication History | Page 3 |
| Section A - Introduction and Purpose | Page 4 |
| Section B - Job Codes and Space Allocation | Page 5 |
| Section C - Work Space Footprint Standards | Page 26 |
| Section D - Functional Support Area Space Standards | Page 39 |
| Section E - Space Analysis | Page 55 |
| Section F - Space Standard Appeals Process | Page 56 |

Publication History

| Issue | Description of Changes | Revision Date | Created By/ Changed By | Requested By |
|--------------|---|----------------------|-----------------------------------|--------------------------------|
| 1.1.9 | Section E-Sample Space Analysis | 7/12/07 | Cheryl Kilwin | Lisa Cavendar |
| 1.1.8 | Section B-Changes in Job Codes | 4/30/07 | Cheryl Kilwin | Amy Wieberg |
| 1.1.7 | Section B-Changes in Job Codes | 4/16/07 | Cheryl Kilwin | Sherry Kempf |
| 1.1.6 | Section D-Change in Functional Support Area Space Standards; changes in Job Codes | 12/26/06 | Cheryl Kilwin | Lisa Cavender and Sherry Kempf |
| 1.1.5 | Section B-Changes in Job Codes. | 10/20/06 | Cheryl Kilwin | Sherry Kempf |
| 1.1.4 | Section D-Change in Functional Support Area Space Standards. | 9/20/06 | Cheryl Kilwin | Sherry Kempf |
| 1.1.3 | Section B-Changes in Job Codes. | 8/11/06 | Cheryl Kilwin | Sherry Kempf/Lisa Cavender |
| 1.1.2 | Section B-Changes in Job Codes. | 8/9/06 | Cheryl Kilwin | Sherry Kempf/ Dave Mosby |
| 1.1.1 | Section B-Changes in Job Codes. | 8/3/06 | Cheryl Kilwin | Sherry Kempf |
| 1.1 | Section B-Changes in Classification; added Section F-Appeals Process | 5/1/06 | Cheryl Kilwin | Sherry Kempf |
| 1.0.3 | Section B-Changes in Functional Support Area Space Standards | 4/20/06 | Cheryl Kilwin | Sherry Kempf |
| 1.0.2 | Section B-Changes in Classification | 4/11/06 | Cheryl Kilwin | Sherry Kempf |
| 1.0.1 | Section B-Change Index # to Title Code; add Publication History page | 4/5/06 | Cheryl Kilwin | Kevin Meinhardt |

SECTION A – INTRODUCTION AND PURPOSE

State of Missouri

Space Planning Guidelines – Individual Work Space and Functional Support Areas

1. Introduction

Over the past ten years, significant changes have occurred in the office environment. The most important changes are in the technological revolution, work culture (e.g. private offices vs. open plan), staffing trends and occupant expectations. The current space standards for the State of Missouri have not been revised since 1992. The State of Missouri has identified the need to update the Space Planning Guidelines. In beginning this process, other states were interviewed to find out how they are classifying space. Based upon the findings, more and more states are going towards open offices rather than private offices. The revised planning guidelines reflect those discussions and are meant to aid the division and the designer in the support of a functional and effective work environment to accommodate these developments.

2. Purpose

Space Guidelines

The goal of the Space Planning Guidelines is to optimize the utilization of the departmental layout. Work spaces are sized for work performed and for job functions. Open office layouts allow people to work in teams and be near the people with whom they work. By going towards the open plan in the work place, costs are being reduced or eliminated on the teardown and reconstruction. Fast rearrangement of workstations to accommodate organizational changes with a minimum amount of time and expense involved. In addition, large file cabinets should be located outside of cubicles in common file storage areas. Common space and meeting rooms should be used as much as possible to reduce the number of meetings happening in workstations.

SECTION B – JOB CODES AND SPACE ALLOCATION

OFFICE OF ADMINISTRATION DIVISION OF FACILITIES MANAGEMENT JOB DESCRIPTION CODES

| TITLE CODE | CLASS TITLE | GRADE | FUNCTIONAL WORK SPACE CODE | WORK SPACE STANDARD | |
|------------|---|-------|----------------------------|---------------------|-------------------------|
| | | | | PRIVATE/ OPEN | PERSONAL SPACE STANDARD |
| 003005 | ACADEMIC TEACHER I | A17 | WKSTN-O-0064 | O | 64 |
| 003006 | ACADEMIC TEACHER II | A21 | WKSTN-O-0064 | O | 64 |
| 003007 | ACADEMIC TEACHER III | A23 | WKSTN-O-0064 | O | 64 |
| 009780 | ACCOUNT CLERK | | WKSTN-O-0064 | O | 64 |
| 000301 | ACCOUNT CLERK I | A08 | WKSTN-O-0048 | O | 48 |
| 000302 | ACCOUNT CLERK II | A12 | WKSTN-O-0064 | O | 64 |
| 009781 | ACCOUNTANT | | WKSTN-O-0064 | O | 64 |
| 000311 | ACCOUNTANT I | A18 | WKSTN-O-0064 | O | 64 |
| 000312 | ACCOUNTANT II | A23 | WKSTN-O-0064 | O | 64 |
| 000313 | ACCOUNTANT III | A26 | WKSTN-O-0096 | O | 96 |
| 000352 | ACCOUNTING ANALYST I | A21 | WKSTN-O-0064 | O | 64 |
| 000353 | ACCOUNTING ANALYST II | A24 | WKSTN-O-0064 | O | 64 |
| 000354 | ACCOUNTING ANALYST III | A28 | WKSTN-O-0096 | O | 96 |
| 000355 | ACCOUNTING ANALYST IV | A32 | WKSTN-O-0120 | O | 120 |
| 000341 | ACCOUNTING SPECIALIST I | A22 | WKSTN-O-0064 | O | 64 |
| 000342 | ACCOUNTING SPECIALIST II | A25 | WKSTN-O-0064 | O | 64 |
| 000345 | ACCOUNTING SPECIALIST III | A29 | WKSTN-O-0096 | O | 96 |
| 009783 | ACCOUNTING SUPERVISOR | | WKSTN-O-0064 | O | 64 |
| 004418 | ACTIVITY AIDE I | A07 | WKSTN-O-0064 | O | 64 |
| 004419 | ACTIVITY AIDE II | A10 | WKSTN-O-0064 | O | 64 |
| 004420 | ACTIVITY AIDE III | A13 | WKSTN-O-0064 | O | 64 |
| 004421 | ACTIVITY THERAPIST | A14 | WKSTN-O-0064 | O | 64 |
| 004427 | ACTIVITY THERAPY COORINATOR | A30 | WKSTN-O-0096 | O | 96 |
| 009779 | ACTUARY | | WKSTN-O-0064 | O | 64 |
| 000004 | ADMINISTRATIVE OFFICE SUPPORT ASSISTANT | A15 | WKSTN-O-0064 | O | 64 |
| 000761 | ADMINISTRATIVE ANALYST I | A17 | WKSTN-O-0064 | O | 64 |
| 000762 | ADMINISTRATIVE ANALYST II | A21 | WKSTN-O-0064 | O | 64 |
| 000763 | ADMINISTRATIVE ANALYST III | A25 | WKSTN-O-0064 | O | 64 |
| 009715 | ADMINISTRATIVE ASSISTANT | | WKSTN-O-0064 | O | 64 |
| 009750 | ADMINISTRATIVE SECRETARY | | WKSTN-O-0064 | O | 64 |
| 000690 | AFFORDABLE HOUSING CONSULTANT (MENTAL HEALTH) | A30 | WKSTN-O-0096 | O | 96 |
| 008561 | AGENT (LIQUOR CONTROL) | A23 | WKSTN-O-0064 | O | 64 |
| 005139 | AGING PROGRAM SPECIALIST I | A22 | WKSTN-O-0064 | O | 64 |
| 005140 | AGING PROGRAM SPECIALIST II | A25 | WKSTN-O-0064 | O | 64 |
| 007566 | AGRICULTURAL EXPORT FACILITY MANAGER | A22 | WKSTN-O-0064 | O | 64 |
| 007570 | AGRICULTURAL LOAN OFFICER | A24 | WKSTN-O-0064 | O | 64 |
| 007562 | AGRICULTURE DEVELOPMENT FUND REPRESENTATIVE | A19 | WKSTN-O-0064 | O | 64 |
| 008082 | AGRICULTURE MANAGER B1 | 1 | WKSTN-O-0120 | O | 120 |
| 008083 | AGRICULTURE MANAGER B2 | 2 | WKSTN-O-0120 | O | 120 |
| 008084 | AGRICULTURE MANAGER B3 | 3 | WKSTN-O-0120 | O | 120 |
| 007560 | AGRICULTURE MARKET REPORTER | A17 | WKSTN-O-0064 | O | 64 |
| 007561 | AGRICULTURE PROMOTION SPECIALIST | A21 | WKSTN-O-0064 | O | 64 |
| 008515 | AIR DEPOT MAINTENANCE SPECIALIST I | A22 | WKSTN-O-0064 | O | 64 |
| 008516 | AIR DEPOT MAINTENANCE SPECIALIST II | A25 | WKSTN-O-0064 | O | 64 |
| 008517 | AIR DEPOT MAINTENANCE SPECIALIST III | A28 | WKSTN-O-0096 | O | 96 |
| 004656 | AIR QUALITY MONITORING SPECIALIST I | A18 | WKSTN-O-0064 | O | 64 |
| 004657 | AIR QUALITY MONITORING SPECIALIST II | A22 | WKSTN-O-0064 | O | 64 |
| 004658 | AIR QUALITY MONITORING SPECIALIST III | A25 | WKSTN-O-0064 | O | 64 |
| 004659 | AIR QUALITY MONITORING SPECIALIST IV | A28 | WKSTN-O-0096 | O | 96 |
| 000645 | AIRCRAFT MAINTENANCE SPECIALIST | A26 | WKSTN-O-0064 | O | 64 |
| 000650 | AIRCRAFT PILOT | A31 | WKSTN-O-0096 | O | 96 |
| 007546 | ANIMAL HEALTH ENFORCEMENT SUPERVISOR | A24 | WKSTN-O-0064 | O | 64 |
| 007542 | ANIMAL HEALTH INSPECTOR | A15 | WKSTN-O-0064 | O | 64 |
| 007545 | ANIMAL HEALTH OFFICER | A18 | WKSTN-O-0064 | O | 64 |

| TITLE CODE | CLASS TITLE | GRADE | FUNCTIONAL WORK SPACE CODE | WORK SPACE STANDARD | |
|------------|---|-------|----------------------------|---------------------|-------------------------|
| | | | | PRIVATE/ OPEN | PERSONAL SPACE STANDARD |
| 007544 | ANIMAL HEALTH PROGRAM COORDINATOR | A28 | WKSTN-O-0096 | O | 96 |
| 000751 | APPEALS REFEREE I | A24 | WKSTN-P-0120 | P | 120* ¹ |
| 000752 | APPEALS REFEREE II | A27 | WKSTN-P-0120 | P | 120* ¹ |
| 000753 | APPEALS REFEREE III | A29 | WKSTN-P-0120 | P | 120* ¹ |
| 007687 | APPRAISAL SPECIALIST | A29 | WKSTN-O-0096 | O | 96 |
| 007681 | APPRAISER I | A17 | WKSTN-O-0064 | O | 64 |
| 007682 | APPRAISER II | A22 | WKSTN-O-0064 | O | 64 |
| 007683 | APPRAISER III | A26 | WKSTN-O-0096 | O | 96 |
| 007685 | APPRAISER SUPERVISOR | A28 | WKSTN-O-0096 | O | 96 |
| 001255 | ARCHAEOLOGIST | A24 | WKSTN-O-0064 | O | 64 |
| 004735 | ARCHITECT I | A28 | WKSTN-O-0096 | O | 96 |
| 004736 | ARCHITECT II | A30 | WKSTN-O-0096 | O | 96 |
| 004737 | ARCHITECT III | A33 | WKSTN-O-0096 | O | 96 |
| 004470 | AREA SUBSTANCE ABUSE TREATMENT COORDINATOR | A28 | WKSTN-O-0096 | O | 96 |
| 005161 | AREA SUPERVISOR BUSINESS ENTERPRISES FOR BLIND | A22 | WKSTN-O-0064 | O | 64 |
| 007780 | ARTS COUNCIL PROGRAM SPECIALIST I | A22 | WKSTN-O-0064 | O | 64 |
| 007781 | ARTS COUNCIL PROGRAM SPECIALIST II | A25 | WKSTN-O-0064 | O | 64 |
| 007675 | ASSESSMENT REPRESENTATIVE I (TAX COMMISSION) | A18 | WKSTN-O-0064 | O | 64 |
| 007676 | ASSESSMENT REPRESENTATIVE II (TAX COMMISSION) | A23 | WKSTN-O-0064 | O | 64 |
| 007634 | ASSISTANT BRANCH OFFICE MANAGER (REVENUE) | A22 | WKSTN-O-0048 | O | 48 |
| 000586 | ASSISTANT CENTER DIRECTOR (ADMINISTRATION) | A27 | WKSTN-O-0096 | O | 96 |
| 000330 | ASSISTANT CONTROLLER (MENTAL HEALTH) | A29 | WKSTN-O-0096 | O | 96 |
| 008503 | ASSISTANT FIRE CHIEF | A27 | WKSTN-O-0064 | O | 64 |
| 000239 | ASSISTANT FORMS MANAGEMENT MANAGER | A27 | WKSTN-O-0096 | O | 96 |
| 009726 | ASSISTANT PROGRAM MANAGER | | WKSTN-O-0096 | O | 96 |
| 009720 | ASSISTANT PROJECT MANAGER | | WKSTN-O-0096 | O | 96 |
| 005176 | ASSISTANT SUPERVISOR (BUSINESS ENTERPRISES FOR BLIND) | A25 | WKSTN-O-0064 | O | 64 |
| 000582 | ASSISTANT SUPERVISOR OF VOLUNTEER SERVICES | A13 | WKSTN-O-0064 | O | 64 |
| 000325 | ASSISTANT TO THE FISCAL OFFICER (MENTAL HEALTH) | A29 | WKSTN-O-0096 | O | 96 |
| 005302 | ASSISTANT VETERANS HOME ADMINISTRATOR | A28 | WKSTN-O-0096 | O | 96 |
| 009722 | ASSOCIATE COUNSEL | | WKSTN-O-0096 | O | 96 |
| 004401 | ASSOCIATE PSYCHOLOGIST II | A25 | WKSTN-O-0064 | O | 64 |
| 004104 | ASSOCIATE PUBLIC HEALTH LABORATOR SCIENTIST | A19 | WKSTN-O-0064 | O | 64 |
| 007860 | ATHLETIC INSPECTOR | A18 | WKSTN-O-0064 | O | 64 |
| ZZ0001 | ATTORNEY | | OFFICE-P-0120 | P | 120* ¹ |
| 009784 | AUDITING SUPERVISOR | | WKSTN-O-0096 | O | 96 |
| 009782 | AUDITOR | | WKSTN-O-0064 | O | 64 |
| 000305 | AUDITOR I | A21 | WKSTN-O-0064 | O | 64 |
| 000304 | AUDITOR II | A24 | WKSTN-O-0064 | O | 64 |
| 000307 | AUDITOR III | A29 | WKSTN-O-0096 | O | 96 |
| 006033 | AUTOMOTIVE EQUIPMENT OFFICER | A25 | WKSTN-O-0064 | O | 64 |
| 002051 | BAKER I | A08 | WKSTN-O-0048 | O | 48 |
| 002052 | BAKER II | A12 | WKSTN-O-0064 | O | 64 |
| 002053 | BAKER III | A14 | WKSTN-O-0064 | O | 64 |
| 006302 | BARBER | A11 | WKSTN-O-0064 | O | 64 |
| 004384 | BEHAVIOR INTERVENTION TECHNICIAN (DEVELOPMENT DISABILITIES) | A13 | WKSTN-O-0064 | O | 64 |
| 004510 | BEHAVIORAL TECHNICIAN | A12 | WKSTN-O-0064 | O | 64 |
| 004511 | BEHAVIORAL TECHNICIAN SUPERVISOR | A15 | WKSTN-O-0064 | O | 64 |
| 004509 | BEHAVIORAL TECHNICIAN TRAINEE | A09 | WKSTN-O-0048 | O | 48 |
| 009742 | BOARD CHAIRMAN | | OFFICE-P-0120 | P | 120* ¹ |
| 009741 | BOARD MEMBER | | OFFICE-P-0120 | P | 120* ¹ |
| 006101 | BOILER OPERATOR | A15 | WKSTN-O-0064 | O | 64 |
| 008576 | BOILER/PRESSURE VESSEL INSPECTOR | A24 | WKSTN-O-0064 | O | 64 |
| 009785 | BUDGET & PLANNING ANALYST | | WKSTN-O-0064 | O | 64 |
| 000390 | BUDGET & PLANNING ANALYST I | A22 | WKSTN-O-0064 | O | 64 |
| 000391 | BUDGET & PLANNING ANALYST II | A26 | WKSTN-O-0096 | O | 96 |
| 000392 | BUDGET & PLANNING SENIOR ANALYST | A29 | WKSTN-O-0096 | O | 96 |
| 009786 | BUDGET & PLANNING SUPERVISOR | | WKSTN-O-0096 | O | 96 |
| 000368 | BUDGET ANALYST I | A18 | WKSTN-O-0064 | O | 64 |
| 000369 | BUDGET ANALYST II | A23 | WKSTN-O-0064 | O | 64 |
| 000370 | BUDGET ANALYST III | A28 | WKSTN-O-0096 | O | 96 |

Statewide Space Standards

Issue Date: July 12, 2007

Proprietary
Version: 1.1.9
Page 6 of 55

| TITLE CODE | CLASS TITLE | GRADE | FUNCTIONAL WORK SPACE CODE | WORK SPACE STANDARD | |
|------------|--|-------|----------------------------|---------------------|-------------------------|
| | | | | PRIVATE/ OPEN | PERSONAL SPACE STANDARD |
| 000371 | BUDGET ANALYST IV | A32 | WKSTN-O-0120 | O | 120 |
| 006042 | BUILDING CONSTRUCTION SUPERVISOR | A20 | WKSTN-O-0064 | O | 64 |
| 006040 | BUILDING CONSTRUCTION WORKER I | A16 | WKSTN-O-0064 | O | 64 |
| 006041 | BUILDING CONSTRUCTION WORKER II | A18 | WKSTN-O-0064 | O | 64 |
| 000540 | BUILDING MANAGER I | A23 | WKSTN-O-0096 | O | 96 |
| 000541 | BUILDING MANAGER II | A26 | WKSTN-O-0096 | O | 96 |
| 007897 | BUSINESS INFORMATION PROGRAM COORDINATOR | A28 | WKSTN-O-0096 | O | 96 |
| 007895 | BUSINESS INFORMATION SPECIALIST I | A18 | WKSTN-O-0064 | O | 64 |
| 007896 | BUSINESS INFORMATION SPECIALIST II | A22 | WKSTN-O-0064 | O | 64 |
| 000221 | BUYER I | A18 | WKSTN-O-0064 | O | 64 |
| 000222 | BUYER II | A23 | WKSTN-O-0064 | O | 64 |
| 000223 | BUYER III | A28 | WKSTN-O-0096 | O | 96 |
| 000224 | BUYER IV | A32 | WKSTN-O-0120 | O | 120 |
| 004702 | CAPITAL IMPROVEMENTS SPECIALIST I | A25 | WKSTN-O-0096 | O | 96 |
| 004703 | CAPITAL IMPROVEMENTS SPECIALIST II | A28 | WKSTN-O-0096 | O | 96 |
| 004704 | CAPITAL IMPROVEMENTS SPECIALIST III | A32 | WKSTN-O-0120 | O | 120 |
| 000665 | CAPITOL POLICE COMMUNICATIONS OPERATOR | A15 | WKSTN-O-0064 | O | 64 |
| 000664 | CAPITOL POLICE COMMUNICATIONS SUPERVISOR | A19 | WKSTN-O-0064 | O | 64 |
| 000663 | CAPITOL POLICE CORPORAL | A22 | WKSTN-O-0064 | O | 64 |
| 000662 | CAPITOL POLICE LIEUTENANT | A28 | WKSTN-O-0120 | O | 120 |
| 000660 | CAPITOL POLICE OFFICER | A20 | WKSTN-O-0064 | O | 64 |
| 000661 | CAPITOL POLICE SERGEANT | A24 | WKSTN-O-0096 | O | 96 |
| 006052 | CARPENTER | A17 | WKSTN-O-0048 | O | 48 |
| 006054 | CARPENTER SUPERVISOR | A19 | WKSTN-O-0064 | O | 64 |
| 005191 | CASE ANALYST | A19 | WKSTN-O-0064 | O | 64 |
| 005192 | CASE ANALYST SUPERVISOR | A21 | WKSTN-O-0096 | O | 96 |
| 004448 | CASE MANAGEMENT/ASSESSMENT SUPERVISOR | A25 | WKSTN-O-0064 | O | 64 |
| 004445 | CASE MANAGER I (DEVELOPMENT DISABILITIES) | A19 | WKSTN-O-0064 | O | 64 |
| 004446 | CASE MANAGER II (DEVELOPMENT DISABILITIES) | A21 | WKSTN-O-0064 | O | 64 |
| 004447 | CASE MANAGER III (DEVELOPMENT DISABILITIES) | A23 | WKSTN-O-0064 | O | 64 |
| 000359 | CENTRAL ACCOUNTING TECHNICIAN | A15 | WKSTN-O-0064 | O | 64 |
| 004557 | CERTIFICATION CONSULTANT (DEVELOPMENT DISABILITIES) | A32 | WKSTN-O-0120 | O | 120 |
| 004001 | CERTIFIED DENTAL ASSISTANT | A12 | WKSTN-O-0064 | O | 64 |
| 009732 | CHAPLAIN | | WKSTN-O-0064 | O | 64 |
| 004111 | CHEMIST I | A19 | WKSTN-O-0064 | O | 64 |
| 004112 | CHEMIST II | A22 | WKSTN-O-0064 | O | 64 |
| 004113 | CHEMIST III | A25 | WKSTN-O-0064 | O | 64 |
| 004114 | CHEMIST IV | A29 | WKSTN-O-0096 | O | 96 |
| 000321 | CHIEF ACCOUNTANT | A28 | WKSTN-O-0096 | O | 96 |
| 009735 | CHIEF COUNSEL | | OFFICE-P-0120 | P | 120* |
| 009737 | CHIEF HEARINGS OFFICER | | WKSTN-O-0096 | O | 96 |
| 001274 | CHIEF PARK RANGER/PROGRAM DIRECTOR | A32 | WKSTN-O-0120 | O | 120 |
| 006365 | CHIEF PHOTOGRAPHER (TOURISM) | A20 | WKSTN-O-0064 | O | 64 |
| 000838 | CHIEF PUBLIC UTILITY ACCOUNTANT | A32 | WKSTN-O-0120 | O | 120 |
| 000658 | CHIEF SECURITY OFFICER | A20 | WKSTN-O-0064 | O | 64 |
| 000842 | CHIEF UTILITY ECONOMIST | A34 | WKSTN-O-0120 | O | 120 |
| 001000 | CHILD CARE FACILITY SPECIALIST I | A18 | WKSTN-O-0064 | O | 64 |
| 001001 | CHILD CARE FACILITY SPECIALIST II | A22 | WKSTN-O-0064 | O | 64 |
| 001002 | CHILD CARE FACILITY SPECIALIST III | A24 | WKSTN-O-0096 | O | 96 |
| 001006 | CHILD CARE PROGRAM SPECIALIST | A26 | WKSTN-O-0096 | O | 96 |
| 005337 | CHILD PLACEMENT COORDINATOR (SOCIAL SERVICES) | A23 | WKSTN-O-0064 | O | 64 |
| 005276 | CHILD SUPPORT ENFORCEMENT ADMINISTRATOR | A24 | WKSTN-O-0096 | O | 96 |
| 005264 | CHILD SUPPORT ENFORCEMENT SPECIALIST | A17 | WKSTN-O-0064 | O | 64 |
| 005274 | CHILD SUPPORT ENFORCEMENT SUPERVISOR | A20 | WKSTN-O-0096 | O | 96 |
| 004468 | CHILDREN & YOUTH SPECIALIST I (PSYCHIATRIC) | A21 | WKSTN-O-0064 | O | 64 |
| 004469 | CHILDREN & YOUTH SPECIALIST II (PSYCHIATRIC) | A23 | WKSTN-O-0064 | O | 64 |
| 004482 | CHILDREN'S PSYCHIATRIC CARE SUPERVISOR | A13 | WKSTN-O-0064 | O | 64 |
| 005186 | CHILDREN'S SERVICE PROGRAM MANAGER | A24 | WKSTN-O-0096 | O | 96 |
| 005201 | CHILDREN'S SERVICE SPECIALIST | A23 | WKSTN-O-0064 | O | 64 |
| 005184 | CHILDREN'S SERVICE SUPERVISOR | A21 | WKSTN-O-0096 | O | 96 |
| 005180 | CHILDREN'S SERVICE WORKER I | A18 | WKSTN-O-0064 | O | 64 |
| 005181 | CHILDREN'S SERVICE WORKER II | A20 | WKSTN-O-0064 | O | 64 |

| TITLE CODE | CLASS TITLE | GRADE | FUNCTIONAL WORK SPACE CODE | WORK SPACE STANDARD | |
|------------|---|-------|----------------------------|---------------------|-------------------------|
| | | | | PRIVATE/ OPEN | PERSONAL SPACE STANDARD |
| 005153 | CHILDREN'S SPECIALIST FOR THE BLIND | A21 | WKSTN-O-0064 | O | 64 |
| 004777 | CIVIL ENGINEER DAM SAFETY | A32 | WKSTN-O-0120 | O | 120 |
| 005260 | CLAIMS & RESTITUTION TECHNICIAN I | A16 | WKSTN-O-0064 | O | 64 |
| 005261 | CLAIMS & RESTITUTION TECHNICIAN II | A19 | WKSTN-O-0064 | O | 64 |
| 000719 | CLAIMS EXAMINER | A14 | WKSTN-O-0064 | O | 64 |
| 000722 | CLAIMS SUPERVISOR II | A21 | WKSTN-O-0064 | O | 64 |
| 000723 | CLAIMS SUPERVISOR III | A24 | WKSTN-O-0064 | O | 64 |
| 000781 | CLAIMS TECHNICIAN I | A17 | WKSTN-O-0064 | O | 64 |
| 000782 | CLAIMS TECHNICIAN II | A19 | WKSTN-O-0064 | O | 64 |
| 000031 | CLERICAL SERVICES SUPERVISOR (FAMILY SERVICES) | A19 | WKSTN-O-0064 | O | 64 |
| 009756 | CLERICAL SUPERVISOR | | WKSTN-O-0064 | O | 64 |
| 009752 | CLERK | | WKSTN-O-0064 | O | 64 |
| 000001 | CLERK I | A06 | WKSTN-O-0064 | O | 64 |
| 004301 | CLIENT ATTENDANT TRAINEE | A05 | WKSTN-O-0048 | O | 48 |
| 009746 | CLIENT/PATIENT WORKER | | WKSTN-O-0064 | O | 64 |
| 005278 | CLINICAL CASEWORK ASSISTANT I | A16 | WKSTN-O-0064 | O | 64 |
| 005279 | CLINICAL CASEWORK ASSISTANT II | A18 | WKSTN-O-0064 | O | 64 |
| 005284 | CLINICAL CASEWORK PRACTITIONER I | A21 | WKSTN-O-0064 | O | 64 |
| 005285 | CLINICAL CASEWORK PRACTITIONER II | A23 | WKSTN-O-0064 | O | 64 |
| 004288 | CLINICAL DIRECTOR I (PSYCHIATRY) | B13 | OFFICE-P-120 | P | 120* ¹ |
| 004289 | CLINICAL DIRECTOR II (PSYCHIATRY) | B14 | OFFICE-P-120 | P | 120* ¹ |
| 004505 | CLINICAL PHARMACIST | A30 | WKSTN-O-0096 | O | 96 |
| 005287 | CLINICAL SOCIAL WORK COORDINATOR | A28 | WKSTN-O-0096 | O | 96 |
| 005280 | CLINICAL SOCIAL WORK SPECIALIST | A25 | WKSTN-O-0064 | O | 64 |
| 005286 | CLINICAL SOCIAL WORK SUPERVISOR | A26 | WKSTN-O-0096 | O | 96 |
| 009740 | COMMISSION CHAIRMAN | | OFFICE-P-0120 | P | 120* ¹ |
| 009739 | COMMISSION MEMBER | | OFFICE-P-0120 | P | 120* ¹ |
| ZZ0002 | COMMISSIONER | | OFFICE-P-0240 | P | 240* ¹ |
| 007325 | COMMUNICATIONS SPECIALIST | A18 | WKSTN-O-0064 | O | 64 |
| 007337 | COMMUNICATIONS WARNING OFFICER | A25 | WKSTN-O-0064 | O | 64 |
| 008091 | COMMUNITY & ECONOMIC DEVELOPMENT MANAGER B1 | 1 | WKSTN-O-0120 | O | 120 |
| 008092 | COMMUNITY & ECONOMIC DEVELOPMENT MANAGER B2 | 2 | WKSTN-O-0120 | O | 120 |
| 008093 | COMMUNITY & ECONOMIC DEVELOPMENT MANAGER B3 | 3 | WKSTN-O-0120 | O | 120 |
| 005294 | COMMUNITY ASSISTANT | A09 | WKSTN-O-0048 | O | 48 |
| 007889 | COMMUNITY DEVELOPMENT PROGRAM SPECIALIST | A25 | WKSTN-O-0096 | O | 96 |
| 007890 | COMMUNITY DEVELOPMENT REPRESENTATIVE I | A18 | WKSTN-O-0064 | O | 64 |
| 007891 | COMMUNITY DEVELOPMENT REPRESENTATIVE II | A22 | WKSTN-O-0064 | O | 64 |
| 007892 | COMMUNITY DEVELOPMENT REPRESENTATIVE III | A24 | WKSTN-O-0064 | O | 64 |
| 004553 | COMMUNITY MENTAL HEALTH SERVICES MANAGER I | A26 | WKSTN-O-0096 | O | 96 |
| 004554 | COMMUNITY MENTAL HEALTH SERVICES MANAGER II | A28 | WKSTN-O-0096 | O | 96 |
| 004552 | COMMUNITY MENTAL HEALTH SERVICES SUPERVISOR | A25 | WKSTN-O-0096 | O | 96 |
| 004385 | COMMUNITY MENTAL HEALTH TECHNICIAN | A11 | WKSTN-O-0064 | O | 64 |
| 005259 | COMMUNITY SERVICES AIDE | A08 | WKSTN-O-0048 | O | 48 |
| 005088 | COMMUNITY SERVICES COORDINATOR (YOUTH SERVICES) | A23 | WKSTN-O-0064 | O | 64 |
| 000361 | COMPLIANCE AUDITOR I | A18 | WKSTN-O-0064 | O | 64 |
| 000362 | COMPLIANCE AUDITOR II | A21 | WKSTN-O-0064 | O | 64 |
| 000363 | COMPLIANCE AUDITOR III | A25 | WKSTN-O-0064 | O | 64 |
| 000151 | COMPUTER INFORMATION TECHNOLOGIST I | A22 | WKSTN-O-0064 | O | 64 |
| 000152 | COMPUTER INFORMATION TECHNOLOGIST II | A25 | WKSTN-O-0064 | O | 64 |
| 000153 | COMPUTER INFORMATION TECHNOLOGIST III | A28 | WKSTN-O-0096 | O | 96 |
| 000198 | COMPUTER INFORMATION TECHNOLOGY MANAGER I | A34 | WKSTN-O-0120 | O | 120 |
| 000197 | COMPUTER INFORMATION TECHNOLOGY MANAGER II | A35 | WKSTN-O-0120 | O | 120 |
| 000165 | COMPUTER INFORMATION TECHNOLOGY SPECIALIST I | A30 | WKSTN-O-0096 | O | 96 |
| 000166 | COMPUTER INFORMATION TECHNOLOGY SPECIALIST II | A33 | WKSTN-O-0120 | O | 120 |
| 000167 | COMPUTER INFORMATION TECHNOLOGY SPECIALIST III | A34 | WKSTN-O-0120 | O | 120 |
| 000157 | COMPUTER INFORMATION TECHNOLOGY SUPERVISOR I | A30 | WKSTN-O-0096 | O | 96 |
| 000158 | COMPUTER INFORMATION TECHNOLOGY SUPERVISOR II | A33 | WKSTN-O-0120 | O | 120 |
| 000150 | COMPUTER INFORMATION TECHNOLOGY TRAINEE | A18 | WKSTN-O-0064 | O | 64 |
| 000136 | COMPUTER OPERATIONS SUPERVISOR I | A23 | WKSTN-O-0064 | O | 64 |
| 000137 | COMPUTER OPERATIONS SUPERVISOR II | A27 | WKSTN-O-0096 | O | 96 |
| 009762 | COMPUTER OPERATOR | | WKSTN-O-0064 | O | 64 |
| 000133 | COMPUTER OPERATOR I | A13 | WKSTN-O-0064 | O | 64 |

| TITLE CODE | CLASS TITLE | GRADE | FUNCTIONAL WORK SPACE CODE | WORK SPACE STANDARD | |
|------------|---|-------|----------------------------|---------------------|-------------------------|
| | | | | PRIVATE/ OPEN | PERSONAL SPACE STANDARD |
| 000134 | COMPUTER OPERATOR II | A17 | WKSTN-O-0064 | O | 64 |
| 000135 | COMPUTER OPERATOR III | A21 | WKSTN-O-0064 | O | 64 |
| 000132 | COMPUTER OPERATOR TRAINEE | A09 | WKSTN-O-0048 | O | 48 |
| 000124 | COMPUTER SUPPORT SERVICES SUPERVISOR | A22 | WKSTN-O-0064 | O | 64 |
| 006144 | CONSTRUCTION INSPECTOR | A26 | WKSTN-O-0096 | O | 96 |
| 006145 | CONSTRUCTION INSPECTOR SUPERVISOR | A28 | WKSTN-O-0096 | O | 96 |
| 009866 | CONSULTING PHYSICIAN | | WKSTN-O-0120 | O | 120 |
| 007589 | CONSUMER SERVICES BRANCH SUPERVISOR | A23 | WKSTN-O-0064 | O | 64 |
| 007588 | CONSUMER SERVICES COORDINATOR | A24 | WKSTN-O-0064 | O | 64 |
| 007585 | CONSUMER SERVICES SPECIALIST I | A18 | WKSTN-O-0064 | O | 64 |
| 007586 | CONSUMER SERVICES SPECIALIST II | A22 | WKSTN-O-0064 | O | 64 |
| 004706 | CONTRACT SPECIALIST I (OFFICE OF ADMINISTRATION) | A22 | WKSTN-O-0064 | O | 64 |
| 004707 | CONTRACT SPECIALIST II (OFFICE OF ADMINISTRATION) | A27 | WKSTN-O-0096 | O | 96 |
| 000729 | CONTRIBUTIONS DEPUTY | A14 | WKSTN-O-0064 | O | 64 |
| 000733 | CONTRIBUTIONS SUPERVISOR II | A21 | WKSTN-O-0064 | O | 64 |
| 000734 | CONTRIBUTIONS SUPERVISOR III | A24 | WKSTN-O-0064 | O | 64 |
| 000783 | CONTRIBUTIONS TECHNICIAN I | A17 | WKSTN-O-0064 | O | 64 |
| 000784 | CONTRIBUTIONS TECHNICIAN II | A19 | WKSTN-O-0064 | O | 64 |
| 009834 | COOK | | WKSTN-O-0048 | O | 48 |
| 002061 | COOK I | A07 | WKSTN-O-0048 | O | 48 |
| 002062 | COOK II | A10 | WKSTN-O-0048 | O | 48 |
| 002063 | COOK III | A15 | WKSTN-O-0048 | O | 48 |
| 000989 | COORDINATOR OF CHILDRENS PROGRAMS | A26 | WKSTN-O-0096 | O | 96 |
| 005169 | COORDINATOR PREVENTION OF BLINDNESS | A26 | WKSTN-O-0096 | O | 96 |
| 005116 | CORRECTIONAL SERVICES TRAINEE (PP/CC) | A18 | WKSTN-O-0064 | O | 64 |
| 005092 | CORRECTIONS CASEWORKER I | A21 | WKSTN-O-0064 | O | 64 |
| 005093 | CORRECTIONS CASEWORKER II | A23 | WKSTN-O-0064 | O | 64 |
| 005020 | CORRECTIONS CLASSIFICATION ASSISTANT | A17 | WKSTN-O-0064 | O | 64 |
| 005015 | CORRECTIONS IDENTIFICATION OFFICER | A15 | WKSTN-O-0064 | O | 64 |
| 005104 | CORRECTIONS INVESTIGATOR I | A21 | WKSTN-O-0064 | O | 64 |
| 005106 | CORRECTIONS LITIGATION COORDINATOR | A21 | WKSTN-O-0064 | O | 64 |
| 008100 | CORRECTIONS MANAGER B1 | 1 | WKSTN-O-0120 | O | 120 |
| 008101 | CORRECTIONS MANAGER B2 | 2 | WKSTN-O-0120 | O | 120 |
| 008102 | CORRECTIONS MANAGER B3 | 3 | WKSTN-O-0120 | O | 120 |
| 005001 | CORRECTIONS OFFICER I | A16 | WKSTN-O-0064 | O | 64 |
| 005002 | CORRECTIONS OFFICER II | A18 | WKSTN-O-0064 | O | 64 |
| 005003 | CORRECTIONS OFFICER III | A20 | WKSTN-O-0064 | O | 64 |
| 005016 | CORRECTIONS RECORDS OFFICER I | A15 | WKSTN-O-0064 | O | 64 |
| 005017 | CORRECTIONS RECORDS OFFICER II | A18 | WKSTN-O-0064 | O | 64 |
| 005018 | CORRECTIONS RECORDS OFFICER III | A22 | WKSTN-O-0064 | O | 64 |
| 005005 | CORRECTIONS SUPERVISOR I | A23 | WKSTN-O-0064 | O | 64 |
| 005006 | CORRECTIONS SUPERVISOR II | A27 | WKSTN-O-0096 | O | 96 |
| 005035 | CORRECTIONS TRAINING OFFICER | A24 | WKSTN-O-0064 | O | 64 |
| 005334 | CORRESPONDENCE & INFORMATION SPECIALIST I | A21 | WKSTN-O-0064 | O | 64 |
| 005335 | CORRESPONDENCE & INFORMATION SPECIALIST II | A24 | WKSTN-O-0064 | O | 64 |
| 006311 | COSMETOLOGIST | A11 | WKSTN-O-0064 | O | 64 |
| 009839 | COUNSELOR | | WKSTN-O-0096 | O | 96 |
| 004439 | COUNSELOR IN TRAINING | A20 | WKSTN-O-0096 | O | 96 |
| 000089 | COURT REPORTER I | A19 | WKSTN-O-0064 | O | 64 |
| 000090 | COURT REPORTER II | A25 | WKSTN-O-0064 | O | 64 |
| 000091 | COURT REPORTER SUPERVISOR | A27 | WKSTN-O-0096 | O | 96 |
| 001209 | CULTURAL RESOURCE PRESERVATIONIST I | A22 | WKSTN-O-0064 | O | 64 |
| 001210 | CULTURAL RESOURCE PRESERVATIONIST II | A25 | WKSTN-O-0064 | O | 64 |
| 001211 | CULTURAL RESOURCE PRESERVATIONIST III | A28 | WKSTN-O-0096 | O | 96 |
| 002003 | CUSTODIAL WORK SUPERVISOR | A10 | WKSTN-O-0048 | O | 48 |
| 002001 | CUSTODIAL WORKER I | A05 | WKSTN-O-0048 | O | 48 |
| 002002 | CUSTODIAL WORKER II | A07 | WKSTN-O-0048 | O | 48 |
| 000186 | DATA BASE ADMINISTRATOR | A34 | WKSTN-O-0120 | O | 120 |
| 000187 | DATA CENTER MANAGER | A32 | WKSTN-O-0120 | O | 120 |
| 000118 | DATA CONTROL CLERK I | A08 | WKSTN-O-0048 | O | 48 |
| 000119 | DATA CONTROL CLERK II | A12 | WKSTN-O-0064 | O | 64 |
| 009760 | DATA ENTRY OPERATOR | | WKSTN-O-0064 | O | 64 |

| TITLE CODE | CLASS TITLE | GRADE | FUNCTIONAL WORK SPACE CODE | WORK SPACE STANDARD | |
|------------|---|-------|----------------------------|---------------------|-------------------------|
| | | | | PRIVATE/ OPEN | PERSONAL SPACE STANDARD |
| 009761 | DATA PROCESSOR, CLERICAL | | WKSTN-O-0064 | O | 64 |
| 009767 | DATA PROCESSOR, CONSULTANT | | WKSTN-O-0064 | O | 64 |
| 009766 | DATA PROCESSOR, MANAGER | | WKSTN-O-0064 | O | 64 |
| 009764 | DATA PROCESSOR, PROFESSIONAL | | WKSTN-O-0064 | O | 64 |
| 009765 | DATA PROCESSOR, SUPERVISOR | | WKSTN-O-0064 | O | 64 |
| 009763 | DATA PROCESSOR, TECHNICAL | | WKSTN-O-0048 | O | 48 |
| 004478 | DEAF & HEARING IMPAIRED SERVICES COORDINATOR | A25 | WKSTN-O-0064 | O | 64 |
| 004002 | DENTAL ASSISTANT | A09 | WKSTN-O-0048 | O | 48 |
| 009849 | DENTAL CONSULTANT | | WKSTN-O-0048 | O | 48 |
| 004003 | DENTAL HYGIENIST | A18 | WKSTN-O-0064 | O | 64 |
| 009847 | DENTIST | | WKSTN-O-0120 | O | 120 |
| 004005 | DENTIST I | A34 | WKSTN-O-0120 | O | 120 |
| 004006 | DENTIST II | A36 | WKSTN-O-0120 | O | 120 |
| 004007 | DENTIST III | A38 | WKSTN-O-0120 | O | 120 |
| ZZ0003 | DEPARTMENT DIRECTOR | | OFFICE-P-0240 | P | 240* ¹ |
| ZZ0004 | DEPUTY COMMISSIONER | | OFFICE-P-0240 | P | 240* ¹ |
| 009749 | DEPUTY COUNSEL | | OFFICE-P-0120 | P | 120* ¹ |
| ZZ0005 | DEPUTY DIRECTOR | | OFFICE-P-0240 | P | 240* ¹ |
| 009706 | DEPUTY DIVISION DIRECTOR (EXEMPT DEPUTY, DIVISION LEVEL) | | OFFICE-P-0240 | P | 240* ¹ |
| 004292 | DEPUTY DIVISION DIRECTOR FOR PSYCHIATRY | B15 | OFFICE-P-0120 | P | 120* ¹ |
| 008504 | DEPUTY FIRE CHIEF | A28 | WKSTN-O-0096 | O | 96 |
| 009702 | DEPUTY STATE DEPARTMENT DIRECTOR (EXEMPT DEPUTY, DEPARTMENT LEVEL) | | OFFICE-P-0240 | P | 240* ¹ |
| 004723 | DESIGN ENGINEER I | A28 | WKSTN-O-0096 | O | 96 |
| 004724 | DESIGN ENGINEER II | A30 | WKSTN-O-0096 | O | 96 |
| 004725 | DESIGN ENGINEER III | A34 | WKSTN-O-0096 | O | 96 |
| 008001 | DESIGN/DEVELOP/SURVEY MANAGER B1 | 1 | WKSTN-O-0120 | O | 120 |
| 008002 | DESIGN/DEVELOP/SURVEY MANAGER B2 | 2 | WKSTN-O-0120 | O | 120 |
| 008003 | DESIGN/DEVELOP/SURVEY MANAGER B3 | 3 | WKSTN-O-0120 | O | 120 |
| 009703 | DESIGNATED PRINCIPAL ASSISTANT, DEPARTMENT LEVEL | | OFFICE-P-0120 | P | 120* ¹ |
| 009707 | DESIGNATED PRINCIPAL ASSISTANT, DIVISION LEVEL | | OFFICE-P-0120 | P | 120* ¹ |
| 004739 | DESIGNER I | A22 | WKSTN-O-0096 | O | 96 |
| 004740 | DESIGNER II | A26 | WKSTN-O-0096 | O | 96 |
| 004741 | DESIGNER III | A29 | WKSTN-O-0096 | O | 96 |
| 004380 | DEVELOPMENTAL ASSISTANT I | A07 | WKSTN-O-0048 | O | 48 |
| 004381 | DEVELOPMENTAL ASSISTANT II | A10 | WKSTN-O-0048 | O | 48 |
| 004382 | DEVELOPMENTAL ASSISTANT III | A13 | WKSTN-O-0048 | O | 48 |
| 002107 | DIETARY SERVICES COORDINATOR (MENTAL HEALTH) | A29 | WKSTN-O-0096 | O | 96 |
| 002101 | DIETITIAN I | A19 | WKSTN-O-0064 | O | 64 |
| 002102 | DIETITIAN II | A22 | WKSTN-O-0064 | O | 64 |
| 002103 | DIETITIAN III | A25 | WKSTN-O-0064 | O | 64 |
| 002104 | DIETITIAN IV | A27 | WKSTN-O-0096 | O | 96 |
| 002071 | DINING ROOM SUPERVISOR | A10 | WKSTN-O-0048 | O | 48 |
| 000866 | DISABILITY PROGRAM REPRESENTATIVE | A22 | WKSTN-O-0064 | O | 64 |
| 000868 | DISABILITY PROGRAM SPECIALIST | A25 | WKSTN-O-0064 | O | 64 |
| 007336 | DISASTER SECTION MANAGER | A28 | WKSTN-O-0096 | O | 96 |
| 001004 | DISTRICT CHILD CARE FACILITY SUPERVISOR | A26 | WKSTN-O-0096 | O | 96 |
| 008563 | DISTRICT SUPERVISOR (LIQUOR CONTROL) | A29 | WKSTN-O-0096 | O | 96 |
| 009709 | DIVISION BUREAU CHIEF | | OFFICE-P-0240 | P | 240* ¹ |
| ZZ0006 | DIVISION COMMISSIONER | | OFFICE-P-0240 | P | 240* ¹ |
| 009705 | DIVISION DIRECTOR | | OFFICE-P-0240 | P | 240* ¹ |
| 009708 | DIVISION SECTION DIRECTOR | | OFFICE-P-0240 | P | 240* ¹ |
| 009832 | DOMESTIC SERVICE CONSULTANT | | WKSTN-O-0048 | O | 48 |
| 009831 | DOMESTIC SERVICE SUPERVISOR (CUSTODIAL FOOD SERVICE, HOUSE KEEPING) | | WKSTN-O-0048 | O | 48 |
| 009830 | DOMESTIC SERVICE WORKER (CUSTODIAL FOOD SERVICE, HOUSE KEEPING) | | WKSTN-O-0048 | O | 48 |
| 004710 | DRAFTER I | A13 | WKSTN-O-0064 | O | 64 |
| 004711 | DRAFTER II | A18 | WKSTN-O-0064 | O | 64 |
| 007900 | ECONOMIC DEVELOPMENT INCENTIVE SPECIALIST I | A18 | WKSTN-O-0064 | O | 64 |
| 007901 | ECONOMIC DEVELOPMENT INCENTIVE SPECIALIST II | A23 | WKSTN-O-0064 | O | 64 |

| TITLE CODE | CLASS TITLE | GRADE | FUNCTIONAL WORK SPACE CODE | WORK SPACE STANDARD | |
|------------|--|-------|----------------------------|---------------------|-------------------------|
| | | | | PRIVATE/ OPEN | PERSONAL SPACE STANDARD |
| 007903 | ECONOMIC DEVELOPMENT INCENTIVE SPECIALIST III | A27 | WKSTN-O-0096 | O | 96 |
| 007790 | ECONOMIC DEVELOPMENT INFORMATION & ADVERTISING COORDINATOR | A26 | WKSTN-O-0096 | O | 96 |
| 008106 | ECONOMIC DEVELOPMENT REGULATORY MANAGER B1 | 1 | WKSTN-O-0120 | O | 120 |
| 008107 | ECONOMIC DEVELOPMENT REGULATORY MANAGER B2 | 2 | WKSTN-O-0120 | O | 120 |
| 008108 | ECONOMIC DEVELOPMENT REGULATORY MANAGER B3 | 3 | WKSTN-O-0120 | O | 120 |
| 000465 | ECONOMIST (OFFICE OF ADMINISTRATION/REVENUE) | A32 | WKSTN-O-0120 | O | 120 |
| 000841 | ECONOMIST (PUBLIC UTILITY) (NATURAL RESOURCES) | A30 | WKSTN-O-0096 | O | 96 |
| 000122 | EDP SCHEDULER | A18 | WKSTN-O-0064 | O | 64 |
| 003031 | EDUCATION ASSISTANT I | A07 | WKSTN-O-0048 | O | 48 |
| 003032 | EDUCATION ASSISTANT II | A10 | WKSTN-O-0048 | O | 48 |
| 003011 | EDUCATION SUPERVISOR I | A26 | WKSTN-O-0096 | O | 96 |
| 009836 | EDUCATIONAL AIDE | | WKSTN-O-0048 | O | 48 |
| 009840 | EDUCATIONAL SUPERVISOR | | WKSTN-O-0096 | O | 96 |
| 006056 | ELECTRICIAN | A17 | WKSTN-O-0064 | O | 64 |
| 006058 | ELECTRICIAN SUPERVISOR | A19 | WKSTN-O-0064 | O | 64 |
| 008802 | ELECTRONIC GAMING DEVICE COORDINATOR | A26 | WKSTN-O-0096 | O | 96 |
| 008801 | ELECTRONIC GAMING DEVICE SPECIALIST | A23 | WKSTN-O-0064 | O | 64 |
| 006087 | ELECTRONICS TECHNICIAN | A18 | WKSTN-O-0064 | O | 64 |
| 008716 | ELEVATOR SAFETY INSPECTOR | A24 | WKSTN-O-0064 | O | 64 |
| 007333 | EMERGENCY MANAGEMENT COORDINATOR | A26 | WKSTN-O-0096 | O | 96 |
| 007331 | EMERGENCY MANAGEMENT OFFICER | A20 | WKSTN-O-0064 | O | 64 |
| 007332 | EMERGENCY MANAGEMENT SPECIALIST | A24 | WKSTN-O-0064 | O | 64 |
| 000980 | EMERGENCY MEDICAL SERVICES INSPECTOR I | A22 | WKSTN-O-0064 | O | 64 |
| 000981 | EMERGENCY MEDICAL SERVICES INSPECTOR II | A25 | WKSTN-O-0064 | O | 64 |
| 006116 | EMERGENCY PROJECT COORDINATOR | A28 | WKSTN-O-0096 | O | 96 |
| 000702 | EMPLOYMENT SECURITY DEPUTY | A14 | WKSTN-O-0064 | O | 64 |
| 000707 | EMPLOYMENT SECURITY SUPERVISOR IV | A27 | WKSTN-O-0096 | O | 96 |
| 005205 | ENERGY ASSISTANCE TECHNICIAN | A11 | WKSTN-O-0048 | O | 48 |
| 004690 | ENERGY ENGINEER I | A27 | WKSTN-O-0096 | O | 96 |
| 004691 | ENERGY ENGINEER II | A30 | WKSTN-O-0096 | O | 96 |
| 004626 | ENERGY SPECIALIST I | A18 | WKSTN-O-0064 | O | 64 |
| 004627 | ENERGY SPECIALIST II | A22 | WKSTN-O-0064 | O | 64 |
| 004628 | ENERGY SPECIALIST III | A25 | WKSTN-O-0064 | O | 64 |
| 004629 | ENERGY SPECIALIST IV | A28 | WKSTN-O-0096 | O | 96 |
| 004760 | ENGINEER DAM SAFETY | A29 | WKSTN-O-0096 | O | 96 |
| 004643 | ENGINEERING CONSULTANT | A33 | WKSTN-O-0120 | O | 120 |
| 008119 | ENTERPRISES MANAGER B1 | 1 | WKSTN-O-0120 | O | 120 |
| 008120 | ENTERPRISES MANAGER B2 | 2 | WKSTN-O-0120 | O | 120 |
| 008121 | ENTERPRISES MANAGER B3 | 3 | WKSTN-O-0120 | O | 120 |
| 009857 | ENVIRONMENTAL AIDE | | WKSTN-O-0048 | O | 48 |
| 000461 | ENVIRONMENTAL EDUCATION & INFORMATION SPECIALIST I | A22 | WKSTN-O-0064 | O | 64 |
| 000462 | ENVIRONMENTAL EDUCATION & INFORMATION SPECIALIST II | A26 | WKSTN-O-0096 | O | 96 |
| 004622 | ENVIRONMENTAL ENGINEER I | A27 | WKSTN-O-0096 | O | 96 |
| 004623 | ENVIRONMENTAL ENGINEER II | A29 | WKSTN-O-0096 | O | 96 |
| 004624 | ENVIRONMENTAL ENGINEER III | A32 | WKSTN-O-0096 | O | 96 |
| 004625 | ENVIRONMENTAL ENGINEER IV | A35 | WKSTN-O-0120 | O | 120 |
| 008010 | ENVIRONMENTAL MANAGER B1 | 1 | WKSTN-O-0120 | O | 120 |
| 008011 | ENVIRONMENTAL MANAGER B2 | 2 | WKSTN-O-0120 | O | 120 |
| 008012 | ENVIRONMENTAL MANAGER B3 | 3 | WKSTN-O-0120 | O | 120 |
| 004612 | ENVIRONMENTAL PUBLIC HEALTH SPECIALIST I | A18 | WKSTN-O-0064 | O | 64 |
| 004613 | ENVIRONMENTAL PUBLIC HEALTH SPECIALIST II | A22 | WKSTN-O-0064 | O | 64 |
| 004614 | ENVIRONMENTAL PUBLIC HEALTH SPECIALIST III | A25 | WKSTN-O-0064 | O | 64 |
| 004615 | ENVIRONMENTAL PUBLIC HEALTH SPECIALIST IV | A27 | WKSTN-O-0096 | O | 96 |
| 004616 | ENVIRONMENTAL PUBLIC HEALTH SPECIALIST V | A28 | WKSTN-O-0096 | O | 96 |
| 004618 | ENVIRONMENTAL SPECIALIST I | A18 | WKSTN-O-0064 | O | 64 |
| 004619 | ENVIRONMENTAL SPECIALIST II | A22 | WKSTN-O-0064 | O | 64 |
| 004620 | ENVIRONMENTAL SPECIALIST III | A25 | WKSTN-O-0064 | O | 64 |
| 004621 | ENVIRONMENTAL SPECIALIST IV | A28 | WKSTN-O-0096 | O | 96 |
| 000930 | EPIDEMIOLOGY SPECIALIST | A25 | WKSTN-O-0064 | O | 64 |
| 009807 | EXECUTIVE (GENERAL ADMINISTRATIVE) | | WKSTN-O-0064 | O | 64 |
| 009713 | EXECUTIVE DIRECTOR | | WKSTN-O-0096 | O | 96 |

Statewide Space Standards

Issue Date: July 12, 2007

Proprietary
Version: 1.1.9
Page 11 of 55

| TITLE CODE | CLASS TITLE | GRADE | FUNCTIONAL WORK SPACE CODE | WORK SPACE STANDARD | |
|------------|--|-------|----------------------------|---------------------|-------------------------|
| | | | | PRIVATE/ OPEN | PERSONAL SPACE STANDARD |
| 000501 | EXECUTIVE I | A18 | WKSTN-O-0064 | O | 64 |
| 000502 | EXECUTIVE II | A22 | WKSTN-O-0064 | O | 64 |
| 009711 | EXECUTIVE SECRETARY | | WKSTN-O-0064 | O | 64 |
| 008019 | FACILITIES OPERATIONS MANAGER B1 | 1 | WKSTN-O-0120 | O | 120 |
| 008020 | FACILITIES OPERATIONS MANAGER B2 | 2 | WKSTN-O-0120 | O | 120 |
| 008021 | FACILITIES OPERATIONS MANAGER B3 | 3 | WKSTN-O-0120 | O | 120 |
| 004365 | FACILITY ADVISORY NURSE I | A24 | WKSTN-O-0064 | O | 64 |
| 004366 | FACILITY ADVISORY NURSE II | A28 | WKSTN-O-0096 | O | 64 |
| 004368 | FACILITY ADVISORY NURSE III | A28 | WKSTN-O-0096 | O | 96 |
| 006148 | FACILITY ASSESSOR I | A28 | WKSTN-O-0096 | O | 96 |
| 006149 | FACILITY ASSESSOR II | A30 | WKSTN-O-0096 | O | 96 |
| 001010 | FACILITY INSPECTOR | A19 | WKSTN-O-0064 | O | 64 |
| 007326 | FACILITY SURVEY ANALYST | A30 | WKSTN-O-0096 | O | 96 |
| 005250 | FACILITY SURVEYOR I | A22 | WKSTN-O-0064 | O | 64 |
| 005251 | FACILITY SURVEYOR II | A25 | WKSTN-O-0064 | O | 64 |
| 005252 | FACILITY SURVEYOR III | A27 | WKSTN-O-0096 | O | 96 |
| 006216 | FACTORY MANAGER I | A21 | WKSTN-O-0064 | O | 64 |
| 006217 | FACTORY MANAGER II | A24 | WKSTN-O-0064 | O | 64 |
| 000673 | FAMILY SELF-SUFFICIENCY COORDINATOR | A23 | WKSTN-O-0064 | O | 64 |
| 005223 | FAMILY SUPPORT ELIGIBILITY PROGRAM MANAGER | A24 | WKSTN-O-0096 | O | 96 |
| 005202 | FAMILY SUPPORT ELIGIBILITY SPECIALIST | A17 | WKSTN-O-0064 | O | 64 |
| 005221 | FAMILY SUPPORT ELIGIBILITY SUPERVISOR | A21 | WKSTN-O-0096 | O | 96 |
| 007521 | FEED & SEED INSPECTOR I | A18 | WKSTN-O-0064 | O | 64 |
| 007522 | FEED & SEED INSPECTOR II | A22 | WKSTN-O-0064 | O | 64 |
| 007523 | FEED & SEED INSPECTOR III | A24 | WKSTN-O-0064 | O | 64 |
| 008810 | FINANCIAL AUDITOR | A28 | WKSTN-O-0096 | O | 96 |
| 006130 | FIRE & SAFETY COORDINATOR | A24 | WKSTN-O-0096 | O | 96 |
| 006131 | FIRE & SAFETY SPECIALIST | A18 | WKSTN-O-0064 | O | 64 |
| 008583 | FIRE INSPECTION SUPERVISOR | A27 | WKSTN-O-0096 | O | 96 |
| 008581 | FIRE INSPECTOR | A22 | WKSTN-O-0064 | O | 64 |
| 008573 | FIRE INVESTIGATION SUPERVISOR | A29 | WKSTN-O-0096 | O | 96 |
| 008571 | FIRE INVESTIGATOR | A25 | WKSTN-O-0064 | O | 64 |
| 008501 | FIREFIGHTER | A19 | WKSTN-O-0064 | O | 64 |
| 008502 | FIREFIGHTER CREW CHIEF | A24 | WKSTN-O-0064 | O | 64 |
| 008028 | FISCAL & ADMINISTRATIVE MANAGER B1 | 1 | WKSTN-O-0120 | O | 120 |
| 008029 | FISCAL & ADMINISTRATIVE MANAGER B2 | 2 | WKSTN-O-0120 | O | 120 |
| 008030 | FISCAL & ADMINISTRATIVE MANAGER B3 | 3 | WKSTN-O-0120 | O | 120 |
| 009788 | FISCAL CONSULTANT | | WKSTN-O-0064 | O | 64 |
| 009787 | FISCAL MANAGER | | WKSTN-O-0064 | O | 64 |
| 007345 | FLOOD PLAIN MANAGEMENT OFFICER | A28 | WKSTN-O-0096 | O | 96 |
| 005306 | FOOD PROGRAM REPRESENTATIVE | A22 | WKSTN-O-0064 | O | 64 |
| 002073 | FOOD SERVICE HELPER I | A05 | WKSTN-O-0048 | O | 48 |
| 002074 | FOOD SERVICE HELPER II | A07 | WKSTN-O-0048 | O | 48 |
| 002066 | FOOD SERVICE MANAGER I | A17 | WKSTN-O-0064 | O | 64 |
| 002067 | FOOD SERVICE MANAGER II | A21 | WKSTN-O-0064 | O | 64 |
| 000246 | FORMS ANALYST I | A16 | WKSTN-O-0064 | O | 64 |
| 000247 | FORMS ANALYST II | A20 | WKSTN-O-0064 | O | 64 |
| 000248 | FORMS ANALYST III | A24 | WKSTN-O-0064 | O | 64 |
| 007536 | FUEL DEVICE SAFETY INSPECTOR | A19 | WKSTN-O-0064 | O | 64 |
| 007539 | FUEL DEVICE SAFETY SPECIALIST | A24 | WKSTN-O-0064 | O | 64 |
| 005100 | FUNCTIONAL UNIT MANAGER (CORRECTIONS) | A24 | WKSTN-O-0064 | O | 64 |
| 007864 | FUNERAL ESTABLISHMENT INSPECTOR | A24 | WKSTN-O-0064 | O | 64 |
| 006034 | GARAGE SUPERVISOR | A19 | WKSTN-O-0064 | O | 64 |
| 000021 | GENERAL OFFICE ASSISTANT | A07 | WKSTN-O-0048 | O | 48 |
| 004813 | GEOGRAPHIC INFORMATION SYSTEMS ANALYST | A26 | WKSTN-O-0096 | O | 96 |
| 004820 | GEOGRAPHIC INFORMATION SYSTEMS COORDINATOR | A34 | WKSTN-O-0120 | O | 120 |
| 004815 | GEOGRAPHIC INFORMATION SYSTEMS SPECIALIST | A30 | WKSTN-O-0096 | O | 96 |
| 004810 | GEOGRAPHIC INFORMATION SYSTEMS TECHNICIAN I | A18 | WKSTN-O-0064 | O | 64 |
| 004811 | GEOGRAPHIC INFORMATION SYSTEMS TECHNICIAN II | A22 | WKSTN-O-0064 | O | 64 |
| 004762 | GEOLOGIST I | A23 | WKSTN-O-0064 | O | 64 |
| 004763 | GEOLOGIST II | A26 | WKSTN-O-0096 | O | 96 |
| 004764 | GEOLOGIST III | A28 | WKSTN-O-0096 | O | 96 |

| TITLE CODE | CLASS TITLE | GRADE | FUNCTIONAL WORK SPACE CODE | WORK SPACE STANDARD | |
|------------|---|-------|----------------------------|---------------------|-------------------------|
| | | | | PRIVATE/ OPEN | PERSONAL SPACE STANDARD |
| 004765 | GEOLOGIST IV | A31 | WKSTN-O-0096 | O | 96 |
| 007508 | GRAIN INSPECTION COMPLIANCE COORDINATOR | A28 | WKSTN-O-0096 | O | 96 |
| 007500 | GRAIN INSPECTOR I | A10 | WKSTN-O-0048 | O | 48 |
| 007501 | GRAIN INSPECTOR II | A15 | WKSTN-O-0048 | O | 48 |
| 007502 | GRAIN INSPECTOR III | A18 | WKSTN-O-0064 | O | 64 |
| 007503 | GRAIN INSPECTOR IV | A23 | WKSTN-O-0064 | O | 64 |
| 007504 | GRAIN INSPECTOR V | A26 | WKSTN-O-0096 | O | 96 |
| 007510 | GRAIN REGULATORY AUDITOR I | A18 | WKSTN-O-0064 | O | 64 |
| 007511 | GRAIN REGULATORY AUDITOR II | A21 | WKSTN-O-0064 | O | 64 |
| 007512 | GRAIN REGULATORY AUDITOR III | A26 | WKSTN-O-0096 | O | 96 |
| 007505 | GRAIN SAMPLER | A08 | WKSTN-O-0048 | O | 48 |
| 006341 | GRAPHIC ARTS SPECIALIST I | A12 | WKSTN-O-0064 | O | 64 |
| 006342 | GRAPHIC ARTS SPECIALIST II | A16 | WKSTN-O-0064 | O | 64 |
| 006343 | GRAPHIC ARTS SPECIALIST III | A22 | WKSTN-O-0064 | O | 64 |
| 006345 | GRAPHICS SUPERVISOR | A24 | WKSTN-O-0064 | O | 64 |
| 006006 | GROUNDSKEEPER I | A10 | WKSTN-O-0048 | O | 48 |
| 006007 | GROUNDSKEEPER II | A13 | WKSTN-O-0048 | O | 48 |
| 003059 | GUIDANCE COUNSELOR I | A20 | WKSTN-O-0096 | O | 96 |
| 003061 | GUIDANCE COUNSELOR II | A23 | WKSTN-O-0096 | O | 96 |
| 004410 | HABILITATION PROGRAM MANAGER | A25 | WKSTN-O-0064 | O | 64 |
| 004407 | HABILITATION SPECIALIST I | A17 | WKSTN-O-0064 | O | 64 |
| 004408 | HABILITATION SPECIALIST II | A21 | WKSTN-O-0064 | O | 64 |
| 004409 | HABILITATION SUPERVISOR | A23 | WKSTN-O-0064 | O | 64 |
| 008174 | HEALTH & SENIOR SERVICES MANAGER B1 | 1 | WKSTN-O-0120 | O | 120 |
| 008175 | HEALTH & SENIOR SERVICES MANAGER B2 | 2 | WKSTN-O-0120 | O | 120 |
| 008176 | HEALTH & SENIOR SERVICES MANAGER B3 | 3 | WKSTN-O-0120 | O | 120 |
| 004330 | HEALTH CARE PRACTITIONER (PHYSICIAN ASSISTANT) (NURSE PRACTITIONER) | A32 | WKSTN-O-0120 | O | 120 |
| 000945 | HEALTH CARE REGULATORY SUPERVISOR | A31 | WKSTN-O-0096 | O | 96 |
| 000911 | HEALTH EDUCATOR I | A18 | WKSTN-O-0064 | O | 64 |
| 000912 | HEALTH EDUCATOR II | A22 | WKSTN-O-0064 | O | 64 |
| 000913 | HEALTH EDUCATOR III | A25 | WKSTN-O-0064 | O | 64 |
| 000941 | HEALTH FACILITIES CONSULTANT | A28 | WKSTN-O-0096 | O | 96 |
| 004356 | HEALTH FACILITIES NURSING CONSULTANT | A31 | WKSTN-O-0096 | O | 96 |
| 000620 | HEALTH INFORMATION ADMINISTRATOR I | A20 | WKSTN-O-0064 | O | 64 |
| 000621 | HEALTH INFORMATION ADMINSTRATOR II | A25 | WKSTN-O-0064 | O | 64 |
| 000618 | HEALTH INFORMATION TECHNICIAN I | A15 | WKSTN-O-0064 | O | 64 |
| 000619 | HEALTH INFORMATION TECHNICIAN II | A17 | WKSTN-O-0064 | O | 64 |
| 000592 | HEALTH PLANNING SPECIALIST | A24 | WKSTN-O-0064 | O | 64 |
| 000574 | HEALTH PROGRAM REPRESENTATIVE I | A18 | WKSTN-O-0064 | O | 64 |
| 000575 | HEALTH PROGRAM REPRESENTATIVE II | A21 | WKSTN-O-0064 | O | 64 |
| 000576 | HEALTH PROGRAM REPRESENTATIVE III | A24 | WKSTN-O-0064 | O | 64 |
| 004550 | HEARINGS ADMINISTRATOR (MENTAL HEALTH) | A28 | WKSTN-O-0096 | O | 96 |
| 005390 | HEARINGS OFFICER | A25 | WKSTN-O-0064 | O | 64 |
| 009736 | HEARINGS OFFICER | | WKSTN-O-0064 | O | 64 |
| 006046 | HEAVY EQUIPMENT MECHANIC | A20 | WKSTN-O-0064 | O | 64 |
| 006045 | HEAVY EQUIPMENT OPERATOR | A17 | WKSTN-O-0064 | O | 64 |
| 006047 | HEAVY EQUIPMENT SUPERVISOR | A21 | WKSTN-O-0064 | O | 64 |
| 005130 | HOME & COMMUNITY SERVICES AREA SUPERVISOR | A25 | WKSTN-O-0096 | O | 96 |
| 001224 | HORTICULTURIST | A21 | WKSTN-O-0048 | O | 48 |
| 000510 | HOSPITAL MANAGEMENT ASSISTANT | A28 | WKSTN-O-0096 | O | 96 |
| 002004 | HOUSEKEEPER I | A16 | WKSTN-O-0064 | O | 64 |
| 002005 | HOUSEKEEPER II | A20 | WKSTN-O-0048 | O | 48 |
| 000683 | HOUSING DEVELOPMENT APPRAISER | A29 | WKSTN-O-0096 | O | 96 |
| 000669 | HOUSING DEVELOPMENT OFFICER I | A19 | WKSTN-O-0064 | O | 64 |
| 000670 | HOUSING DEVELOPMENT OFFICER II | A21 | WKSTN-O-0064 | O | 64 |
| 000685 | HOUSING PROGRAM AUDITOR & INSPECTOR | A27 | WKSTN-O-0096 | O | 96 |
| 000676 | HOUSING PROGRAM LOAN ADMINISTRATOR | A27 | WKSTN-O-0096 | O | 96 |
| 000407 | HUMAN RELATIONS OFFICER I | A24 | WKSTN-O-0096 | O | 96 |
| 000408 | HUMAN RELATIONS OFFICER II | A26 | WKSTN-O-0096 | O | 96 |
| 000409 | HUMAN RELATIONS OFFICER III | A28 | WKSTN-O-0096 | O | 96 |
| 000406 | HUMAN RELATIONS TECHNICIAN | A18 | WKSTN-O-0064 | O | 64 |

Statewide Space Standards

Issue Date: July 12, 2007

Proprietary
Version: 1.1.9
Page 13 of 55

| TITLE CODE | CLASS TITLE | GRADE | FUNCTIONAL WORK SPACE CODE | WORK SPACE STANDARD | |
|------------|--|-------|----------------------------|---------------------|-------------------------|
| | | | | PRIVATE/ OPEN | PERSONAL SPACE STANDARD |
| 008037 | HUMAN RESOURCES MANAGER B1 | 1 | WKSTN-O-0120 | O | 120 |
| 008038 | HUMAN RESOURCES MANAGER B2 | 2 | WKSTN-O-0120 | O | 120 |
| 008039 | HUMAN RESOURCES MANAGER B3 | 3 | WKSTN-O-0120 | O | 120 |
| 006105 | HVAC-INSTRUMENT CONTROLS TECHNICIAN | A18 | WKSTN-O-0064 | O | 64 |
| 004793 | HYDROLOGIST I | A23 | WKSTN-O-0064 | O | 64 |
| 004794 | HYDROLOGIST II | A26 | WKSTN-O-0096 | O | 96 |
| 004795 | HYDROLOGIST III | A28 | WKSTN-O-0096 | O | 96 |
| 004796 | HYDROLOGIST IV | A31 | WKSTN-O-0096 | O | 96 |
| 009798 | INFORMATION CONSULTANT | | WKSTN-O-0064 | O | 64 |
| 009797 | INFORMATION SUPERVISOR | | WKSTN-O-0064 | O | 64 |
| 000130 | INFORMATION SUPPORT COORDINATOR | A16 | WKSTN-O-0064 | O | 64 |
| 009796 | INFORMATIONAL WORKER | | WKSTN-O-0064 | O | 64 |
| 009747 | INMATE WORKER | | WKSTN-O-0048 | O | 48 |
| 009820 | INSPECTOR | | WKSTN-O-0064 | O | 64 |
| 007862 | INSPECTOR (PROFESSIONAL REGISTRATION) | A16 | WKSTN-O-0064 | O | 64 |
| 007863 | INSPECTOR SUPERVISOR (PROFESSIONAL REGISTRATION) | A18 | WKSTN-O-0064 | O | 64 |
| 009731 | INSTITUTION SUPERINTENDENT | | OFFICE-P-0120 | P | 120* ¹ |
| 005029 | INSTITUTIONAL ACTIVITY COORDINATOR | A17 | WKSTN-O-0064 | O | 64 |
| 009837 | INSTRUCTOR | | WKSTN-O-0064 | O | 64 |
| 009818 | INSURANCE ASSISTANT CHIEF, FINANCIAL/MARKET CONDUCT | | WKSTN-O-0096 | O | 96 |
| 009817 | INSURANCE AUDIT MANAGER, FINANCIAL/MARKET CONDUCT | | WKSTN-O-0064 | O | 64 |
| 009815 | INSURANCE EXAMINER, FINANCIAL/MARKET CONDUCT | | WKSTN-O-0064 | O | 64 |
| 009816 | INSURANCE EXAMINER-IN-CHARGE, FINANCIAL/MARKET CONDUCT | | WKSTN-O-0064 | O | 64 |
| 007579 | INSURANCE FINANCIAL ANALYSIS SPECIALST | A25 | WKSTN-O-0064 | O | 64 |
| 007582 | INSURANCE FINANCIAL ANALYST I | A18 | WKSTN-O-0064 | O | 64 |
| 007583 | INSURANCE FINANCIAL ANALYST II | A23 | WKSTN-O-0064 | O | 64 |
| 007593 | INSURANCE LICENSING TECHNICIAN I | A10 | WKSTN-O-0064 | O | 64 |
| 007594 | INSURANCE LICENSING TECHNICIAN II | A13 | WKSTN-O-0064 | O | 64 |
| 007575 | INSURANCE PRODUCT ANALYST I | A18 | WKSTN-O-0064 | O | 64 |
| 007576 | INSURANCE PRODUCT ANALYST II | A20 | WKSTN-O-0064 | O | 64 |
| 007577 | INSURANCE PRODUCT ANALYST III | A22 | WKSTN-O-0064 | O | 64 |
| 008128 | INSURANCE REGULATORY MANAGER B1 | 1 | WKSTN-O-0120 | O | 120 |
| 008129 | INSURANCE REGULATORY MANAGER B2 | 2 | WKSTN-O-0120 | O | 120 |
| 008130 | INSURANCE REGULATORY MANAGER B3 | 3 | WKSTN-O-0120 | O | 120 |
| 007581 | INSURANCE SURPLUS LINES SPECIALIST | A19 | WKSTN-O-0064 | O | 64 |
| 007598 | INSURANCE TAX AUDIT SPECIALIST | A23 | WKSTN-O-0064 | O | 64 |
| 007563 | INTERNATIONAL MARKETING SPECIALIST | A24 | WKSTN-O-0064 | O | 64 |
| 004477 | INTERPRETER/TRANSLITERATOR | A20 | WKSTN-O-0064 | O | 64 |
| 001263 | INTERPRETIVE RESOURCE COORDINATOR | A26 | WKSTN-O-0096 | O | 96 |
| 001260 | INTERPRETIVE RESOURCE SPECIALIST I | A18 | WKSTN-O-0064 | O | 64 |
| 001261 | INTERPRETIVE RESOURCE SPECIALIST II | A21 | WKSTN-O-0064 | O | 64 |
| 001262 | INTERPRETIVE RESOURCE SPECIALIST III | A24 | WKSTN-O-0064 | O | 64 |
| 001259 | INTERPRETIVE RESOURCE TECHNICIAN | A16 | WKSTN-O-0064 | O | 64 |
| 008046 | INVESTIGATION MANAGER B1 | 1 | WKSTN-O-0120 | O | 120 |
| 008047 | INVESTIGATION MANAGER B2 | 2 | WKSTN-O-0120 | O | 120 |
| 008048 | INVESTIGATION MANAGER B3 | 3 | WKSTN-O-0120 | O | 120 |
| 005296 | INVESTIGATOR I | A18 | WKSTN-O-0064 | O | 64 |
| 005297 | INVESTIGATOR II | A23 | WKSTN-O-0064 | O | 64 |
| 005298 | INVESTIGATOR III | A25 | WKSTN-O-0064 | O | 64 |
| 009835 | JANITOR | | WKSTN-O-0048 | O | 48 |
| 005159 | JOB DEVELOPMENT SPECIALIST FOR THE BLIND | A23 | WKSTN-O-0064 | O | 64 |
| 000792 | JOB TRAINING PROGRAM SPECIALIST I | A22 | WKSTN-O-0064 | O | 64 |
| 000793 | JOB TRAINING PROGRAM SPECIALIST II | A25 | WKSTN-O-0064 | O | 64 |
| 008137 | LABOR & INDUSTRIAL RELATIONS MANAGER B1 | 1 | WKSTN-O-0120 | O | 120 |
| 008138 | LABOR & INDUSTRIAL RELATIONS MANAGER B2 | 2 | WKSTN-O-0120 | O | 120 |
| 008139 | LABOR & INDUSTRIAL RELATIONS MANAGER B3 | 3 | WKSTN-O-0120 | O | 120 |
| 000463 | LABOR ECONOMIST | A28 | WKSTN-O-0096 | O | 96 |
| 009801 | LABOR RELATIONS CONSULTANT | | WKSTN-O-0064 | O | 64 |
| 006005 | LABOR SUPERVISOR | A13 | WKSTN-O-0064 | O | 64 |
| 009850 | LABORATORY AIDE | | WKSTN-O-0048 | O | 48 |
| 004102 | LABORATORY ASSISTANT | A06 | WKSTN-O-0048 | O | 48 |

Statewide Space Standards

Issue Date: July 12, 2007

Proprietary
Version: 1.1.9
Page 14 of 55

| TITLE CODE | CLASS TITLE | GRADE | FUNCTIONAL WORK SPACE CODE | WORK SPACE STANDARD | |
|------------|--|-------|----------------------------|---------------------|-------------------------|
| | | | | PRIVATE/ OPEN | PERSONAL SPACE STANDARD |
| 008055 | LABORATORY MANAGER B1 | 1 | WKSTN-O-0120 | O | 120 |
| 008056 | LABORATORY MANAGER B2 | 2 | WKSTN-O-0120 | O | 120 |
| 008057 | LABORATORY MANAGER B3 | 3 | WKSTN-O-0120 | O | 120 |
| 004170 | LABORATORY TECHNICIAN | A09 | WKSTN-O-0048 | O | 48 |
| 009851 | LABORATORY TECHNICIAN | | WKSTN-O-0048 | O | 48 |
| 006001 | LABORER I | A06 | WKSTN-O-0048 | O | 48 |
| 006002 | LABORER II | A09 | WKSTN-O-0048 | O | 48 |
| 004754 | LAND SURVEY SPECIALIST I | A16 | WKSTN-O-0064 | O | 64 |
| 004755 | LAND SURVEY SPECIALIST II | A20 | WKSTN-O-0064 | O | 64 |
| 004801 | LAND SURVEYOR I | A27 | WKSTN-O-0096 | O | 96 |
| 004802 | LAND SURVEYOR II | A29 | WKSTN-O-0096 | O | 96 |
| 004800 | LAND SURVEYOR-IN-TRAINING | A25 | WKSTN-O-0064 | O | 64 |
| 004774 | LANDSCAPE DESIGNER I | A23 | WKSTN-O-0096 | O | 96 |
| 004775 | LANDSCAPE DESIGNER II | A25 | WKSTN-O-0096 | O | 96 |
| 002028 | LAUNDRY MANAGER I | A17 | WKSTN-O-0064 | O | 64 |
| 002029 | LAUNDRY MANAGER II | A21 | WKSTN-O-0064 | O | 64 |
| 002026 | LAUNDRY SUPERVISOR | A14 | WKSTN-O-0064 | O | 64 |
| 002023 | LAUNDRY WORKER I | A05 | WKSTN-O-0048 | O | 48 |
| 002024 | LAUNDRY WORKER II | A07 | WKSTN-O-0048 | O | 48 |
| 008064 | LAW ENFORCEMENT MANAGER B1 | 1 | WKSTN-O-0120 | O | 120 |
| 008065 | LAW ENFORCEMENT MANAGER B2 | 2 | WKSTN-O-0120 | O | 120 |
| 008066 | LAW ENFORCEMENT MANAGER B3 | 3 | WKSTN-O-0120 | O | 120 |
| 009734 | LEGAL COUNSEL | | OFFICE-P-0120 | P | 120* |
| 000743 | LEGISLATIVE COORDINATOR | A29 | WKSTN-O-0096 | O | 96 |
| 003020 | LIBRARIAN I | A17 | WKSTN-O-0064 | O | 64 |
| 003021 | LIBRARIAN II | A20 | WKSTN-O-0064 | O | 64 |
| 005283 | LICENSED CLINICAL SOCIAL WORKER | A24 | WKSTN-O-0064 | O | 64 |
| 004317 | LICENSED PRACTICAL NURSE I (GENERAL) | A14 | WKSTN-O-0064 | O | 64 |
| 004318 | LICENSED PRACTICAL NURSE II (GENERAL) | A15 | WKSTN-O-0064 | O | 64 |
| 004319 | LICENSED PRACTICAL NURSE III (GENERAL) | A18 | WKSTN-O-0064 | O | 64 |
| 004440 | LICENSED PROFESSIONAL COUNSELOR I | A22 | WKSTN-O-0096 | O | 96 |
| 004441 | LICENSED PROFESSIONAL COUNSELOR II | A24 | WKSTN-O-0096 | O | 96 |
| 000633 | LOAN SERVICING OFFICER | A27 | WKSTN-O-0096 | O | 96 |
| 006026 | LOCKSMITH | A17 | WKSTN-O-0064 | O | 64 |
| 005138 | LONG-TERM CARE SPECIALIST | A21 | WKSTN-O-0064 | O | 64 |
| 008141 | LOTTERY MANAGER B1 | 1 | WKSTN-O-0120 | O | 120 |
| 008142 | LOTTERY MANAGER B2 | 2 | WKSTN-O-0120 | O | 120 |
| 008143 | LOTTERY MANAGER B3 | 3 | WKSTN-O-0120 | O | 120 |
| 007954 | LOTTERY SALES COORDINATOR | A24 | WKSTN-O-0064 | O | 64 |
| 007952 | LOTTERY SALES REPRESENTATIVE | A20 | WKSTN-O-0064 | O | 64 |
| 007950 | LOTTERY SALES TECHNICIAN | A13 | WKSTN-O-0064 | O | 64 |
| 007962 | LOTTERY SECURITY SPECIALIST | A28 | WKSTN-O-0096 | O | 96 |
| 006060 | MACHINIST | A17 | WKSTN-O-0064 | O | 64 |
| 000063 | MAIL ROOM SUPERVISOR | A18 | WKSTN-O-0064 | O | 64 |
| 000060 | MAILING EQUIPMENT OPERATOR | A12 | WKSTN-O-0064 | O | 64 |
| 006014 | MAINTENANCE SUPERVISOR I | A19 | WKSTN-O-0064 | O | 64 |
| 006015 | MAINTENANCE SUPERVISOR II | A21 | WKSTN-O-0064 | O | 64 |
| 006011 | MAINTENANCE WORKER I | A13 | WKSTN-O-0064 | O | 64 |
| 006012 | MAINTENANCE WORKER II | A16 | WKSTN-O-0064 | O | 64 |
| 000552 | MANAGEMENT ANALYSIS SPECIALIST I | A23 | WKSTN-O-0064 | O | 64 |
| 000553 | MANAGEMENT ANALYSIS SPECIALIST II | A26 | WKSTN-O-0096 | O | 96 |
| 009804 | MANAGEMENT ANALYST (GENERAL ADMINISTRATIVE) | | WKSTN-O-0064 | O | 64 |
| 00756 | MANAGEMENT ANALYST I (EMPLOYMENT SECURITY) | A21 | WKSTN-O-0064 | O | 64 |
| 000757 | MANAGEMENT ANALYST II (EMPLOYMENT SECURITY) | A24 | WKSTN-O-0064 | O | 64 |
| 000758 | MANAGEMENT ANALYST III (EMPLOYMENT SECURITY) | A27 | WKSTN-O-0096 | O | 96 |
| 009805 | MANAGEMENT CONSULTANT (GENERAL ADMINISTRATIVE) | | WKSTN-O-0064 | O | 64 |
| 009808 | MANAGER (GENERAL ADMINISTRATIVE) | | WKSTN-O-0120 | O | 120 |
| 000138 | MANAGER OF DATA PROCESSING OPERATIONS | A30 | WKSTN-O-0096 | O | 96 |
| 007813 | MANAGER, ECONOMIC ANALYSIS | A34 | WKSTN-O-0120 | O | 120 |
| 007822 | MANAGER, UTILITY POLICY & FEDERAL AFFAIRS | A33 | WKSTN-O-0120 | O | 120 |
| 007850 | MANUFACTURED HOUSING INSPECTOR I | A18 | WKSTN-O-0064 | O | 64 |
| 007849 | MANUFACTURED HOUSING INSPECTOR II | A22 | WKSTN-O-0064 | O | 64 |

| TITLE CODE | CLASS TITLE | GRADE | FUNCTIONAL WORK SPACE CODE | WORK SPACE STANDARD | |
|------------|--|-------|----------------------------|---------------------|-------------------------|
| | | | | PRIVATE/ OPEN | PERSONAL SPACE STANDARD |
| 007851 | MANUFACTURED HOUSING INSPECTOR SUPERVISOR | A24 | WKSTN-O-0064 | O | 64 |
| 006051 | MARINE MECHANIC | A17 | WKSTN-O-0064 | O | 64 |
| 007564 | MARKET DEVELOPMENT PROGRAM COORDINATOR | A28 | WKSTN-O-0096 | O | 96 |
| 007885 | MARKETING SPECIALIST I | A18 | WKSTN-O-0064 | O | 64 |
| 007886 | MARKETING SPECIALIST II | A24 | WKSTN-O-0064 | O | 64 |
| 007887 | MARKETING SPECIALIST III | A27 | WKSTN-O-0096 | O | 96 |
| 000874 | MEDIATOR | A24 | WKSTN-O-0064 | O | 64 |
| 005340 | MEDICAID CLERK | A15 | WKSTN-O-0064 | O | 64 |
| 005338 | MEDICAID PHARMACEUTICAL TECHNICIAN | A19 | WKSTN-O-0064 | O | 64 |
| 005331 | MEDICAID PROGRAM RELATIONS REPRESENTATIVE | A24 | WKSTN-O-0064 | O | 64 |
| 005342 | MEDICAID SPECIALIST | A23 | WKSTN-O-0064 | O | 64 |
| 005341 | MEDICAID TECHNICIAN | A19 | WKSTN-O-0064 | O | 64 |
| 005344 | MEDICAID UNIT SUPERVISOR | A26 | WKSTN-O-0096 | O | 96 |
| 009865 | MEDICAL ADMINISTRATOR | | WKSTN-O-0064 | O | 64 |
| 004282 | MEDICAL CONSULTANT | B08 | WKSTN-O-0120 | O | 120 |
| 004286 | MEDICAL DIRECTOR | B09 | OFFICE-P-0120 | P | 120*1 |
| 009860 | MEDICAL EXTERN | | WKSTN-O-0036 | O | 36 |
| 004150 | MEDICAL LABORATORY TECHNICIAN I | A09 | WKSTN-O-0048 | O | 48 |
| 004151 | MEDICAL LABORATORY TECHNICIAN II | A12 | WKSTN-O-0064 | O | 64 |
| 004280 | MEDICAL SPECIALIST I | B06 | WKSTN-O-0120 | O | 120 |
| 004281 | MEDICAL SPECIALIST II | B07 | WKSTN-O-0120 | O | 120 |
| 004153 | MEDICAL TECHNOLOGIST I | A18 | WKSTN-O-0064 | O | 64 |
| 004154 | MEDICAL TECHNOLOGIST II | A21 | WKSTN-O-0064 | O | 64 |
| 004155 | MEDICAL TECHNOLOGIST III | A24 | WKSTN-O-0064 | O | 64 |
| 004152 | MEDICAL TECHNOLOGIST TRAINEE | A15 | WKSTN-O-0064 | O | 64 |
| 004507 | MENTAL HEALTH COORDINATOR I | A26 | WKSTN-O-0096 | O | 96 |
| 004508 | MENTAL HEALTH COORDINATOR II | A28 | WKSTN-O-0096 | O | 96 |
| 008146 | MENTAL HEALTH MANAGER B1 | 1 | WKSTN-O-0120 | O | 120 |
| 008147 | MENTAL HEALTH MANAGER B2 | 2 | WKSTN-O-0120 | O | 120 |
| 008148 | MENTAL HEALTH MANAGER B3 | 3 | WKSTN-O-0120 | O | 120 |
| 007534 | METROLOGY SPECIALIST | A22 | WKSTN-O-0064 | O | 64 |
| 008535 | MILITARY FUNERAL HONORS AREA COORDINATOR | A18 | WKSTN-O-0064 | O | 64 |
| 008537 | MILITARY FUNERAL HONORS AREA SUPERVISOR | A22 | WKSTN-O-0064 | O | 64 |
| 008539 | MILITARY FUNERAL HONORS OPERATIONS COORDINATOR | A22 | WKSTN-O-0064 | O | 64 |
| 008533 | MILITARY FUNERAL HONORS TEAM LEADER | A15 | WKSTN-O-0064 | O | 64 |
| 008531 | MILITARY FUNERAL HONORS TEAM MEMBER | A12 | WKSTN-O-0064 | O | 64 |
| 008511 | MILITARY SECURITY ADMINISTRATOR | A26 | WKSTN-O-0096 | O | 96 |
| 008508 | MILITARY SECURITY OFFICER I | A17 | WKSTN-O-0064 | O | 64 |
| 008509 | MILITARY SECURITY OFFICER II | A19 | WKSTN-O-0064 | O | 64 |
| 008510 | MILITARY SECURITY SUPERVISOR | A22 | WKSTN-O-0064 | O | 64 |
| 000895 | MINE INSPECTOR | A23 | WKSTN-O-0064 | O | 64 |
| 000876 | MINE SAFETY INSTRUCTOR | A22 | WKSTN-O-0064 | O | 64 |
| 006142 | MINORITY CONTRACTS COORDINATOR | A28 | WKSTN-O-0096 | O | 96 |
| 000230 | MINORITY PURCHASING ASSISTANT | A14 | WKSTN-O-0064 | O | 64 |
| 000229 | MINORITY/WOMEN CERTIFICATION COORDINATOR | A25 | WKSTN-O-0064 | O | 64 |
| 000228 | MINORITY/WOMEN PURCHASING COORDINATOR | A28 | WKSTN-O-0096 | O | 96 |
| 009813 | MISCELLANEOUS ADMINISTRATIVE | | WKSTN-O-0064 | O | 64 |
| 009811 | MISCELLANEOUS PROFESSIONAL | | WKSTN-O-0064 | O | 64 |
| 009812 | MISCELLANEOUS SUPERVISORY | | WKSTN-O-0096 | O | 96 |
| 009810 | MISCELLANEOUS TECHNICAL | | WKSTN-O-0048 | O | 48 |
| 005156 | MOBILITY SPECIALIST FOR THE BLIND | A23 | WKSTN-O-0064 | O | 64 |
| 006021 | MOTOR VEHICLE DRIVER | A10 | WKSTN-O-0048 | O | 48 |
| 006031 | MOTOR VEHICLE MECHANIC | A17 | WKSTN-O-0064 | O | 64 |
| 001207 | MUSEUM CURATOR | A20 | WKSTN-O-0064 | O | 64 |
| 004455 | MUSIC THERAPIST I | A19 | WKSTN-O-0064 | O | 64 |
| 004456 | MUSIC THERAPIST II | A22 | WKSTN-O-0064 | O | 64 |
| 004457 | MUSIC THERAPIST III | A24 | WKSTN-O-0064 | O | 64 |
| 008155 | NATURAL RESOURCES MANAGER B1 | 1 | WKSTN-O-0120 | O | 120 |
| 008156 | NATURAL RESOURCES MANAGER B2 | 2 | WKSTN-O-0120 | O | 120 |
| 008157 | NATURAL RESOURCES MANAGER B3 | 3 | WKSTN-O-0120 | O | 120 |
| 001217 | NATURAL RESOURCES STEWARD | A25 | WKSTN-O-0064 | O | 64 |
| 004311 | NURSING ASSISTANT I | A06 | WKSTN-O-0048 | O | 48 |

Statewide Space Standards

Issue Date: July 12, 2007

Proprietary
Version: 1.1.9
Page 16 of 55

| TITLE CODE | CLASS TITLE | GRADE | FUNCTIONAL WORK SPACE CODE | WORK SPACE STANDARD | |
|------------|---|-------|----------------------------|---------------------|-------------------------|
| | | | | PRIVATE/ OPEN | PERSONAL SPACE STANDARD |
| 004312 | NURSING ASSISTANT II | A09 | WKSTN-O-0048 | O | 48 |
| 002114 | NUTRITION SPECIALIST | A27 | WKSTN-O-0096 | O | 96 |
| 008070 | NUTRITION/DIETARY SERVICES MANAGER B1 | 1 | WKSTN-O-0120 | O | 120 |
| 008071 | NUTRITION/DIETARY SERVICES MANAGER B2 | 2 | WKSTN-O-0120 | O | 120 |
| 008072 | NUTRITION/DIETARY SERVICES MANAGER B3 | 3 | WKSTN-O-0120 | O | 120 |
| 002110 | NUTRITIONIST I | A18 | WKSTN-O-0064 | O | 64 |
| 002111 | NUTRITIONIST II | A22 | WKSTN-O-0064 | O | 64 |
| 002112 | NUTRITIONIST III | A24 | WKSTN-O-0064 | O | 64 |
| 000873 | OCCUPATIONAL HEALTH CONSULTANT (WORK COMP) | A27 | WKSTN-O-0096 | O | 96 |
| 000777 | OCCUPATIONAL RESEARCH ANALYST I | A22 | WKSTN-O-0064 | O | 64 |
| 000778 | OCCUPATIONAL RESEARCH ANALYST II | A25 | WKSTN-O-0064 | O | 64 |
| 000892 | OCCUPATIONAL SAFETY & HEALTH CONSULTANT I | A21 | WKSTN-O-0064 | O | 64 |
| 000893 | OCCUPATIONAL SAFETY & HEALTH CONSULTANT II | A25 | WKSTN-O-0064 | O | 64 |
| 000894 | OCCUPATIONAL SAFETY & HEALTH CONSULTANT III | A27 | WKSTN-O-0096 | O | 96 |
| 000896 | OCCUPATIONAL SAFETY & HEALTH SUPERVISOR | A29 | WKSTN-O-0096 | O | 96 |
| 004423 | OCCUPATIONAL THERAPIST I | A24 | WKSTN-O-0064 | O | 64 |
| 004424 | OCCUPATIONAL THERAPIST II | A27 | WKSTN-O-0096 | O | 96 |
| 004425 | OCCUPATIONAL THERAPIST III | A29 | WKSTN-O-0096 | O | 96 |
| 004422 | OCCUPATIONAL THERAPY ASSISTANT | A16 | WKSTN-O-0064 | O | 64 |
| 009717 | OFFICE MANAGER | | WKSTN-O-0096 | O | 96 |
| 008165 | OFFICE OF ADMINISTRATION MANAGER B1 | 1 | WKSTN-O-0120 | O | 120 |
| 008166 | OFFICE OF ADMINISTRATION MANAGER B2 | 2 | WKSTN-O-0120 | O | 120 |
| 008167 | OFFICE OF ADMINISTRATION MANAGER B3 | 3 | WKSTN-O-0120 | O | 120 |
| 000035 | OFFICE SERVICES ASSISTANT | A16 | WKSTN-O-0064 | O | 64 |
| 000243 | OFFICE SERVICES COORDINATOR I | A26 | WKSTN-O-0096 | O | 96 |
| 000002 | OFFICE SUPPORT ASSISTANT (CLERICAL) | A08 | WKSTN-O-0064 | O | 64 |
| 000022 | OFFICE SUPPORT ASSISTANT (KEYBRD) | A09 | WKSTN-O-0064 | O | 64 |
| 000012 | OFFICE SUPPORT ASSISTANT (STENO) | A10 | WKSTN-O-0064 | O | 64 |
| 009755 | OFFICE WORKER, MISCELLANEOUS | | WKSTN-O-0064 | O | 64 |
| 005032 | OUTDOOR REHABILITATION COUNSELOR I | A21 | WKSTN-O-0096 | O | 96 |
| 005033 | OUTDOOR REHABILITATION COUNSELOR II | A23 | WKSTN-O-0096 | O | 96 |
| 009714 | OUT-STATE AUDIT PERSONNEL | | WKSTN-O-0064 | O | 64 |
| 006066 | PAINTER | A17 | WKSTN-O-0064 | O | 64 |
| 006068 | PAINTER SUPERVISOR | A19 | WKSTN-O-0064 | O | 64 |
| 009730 | PARALEGAL | | WKSTN-O-0096 | O | 96 |
| 006048 | PARK MAINTENANCE WORKER I | A10 | WKSTN-O-0048 | O | 48 |
| 006049 | PARK MAINTENANCE WORKER II | A13 | WKSTN-O-0048 | O | 48 |
| 006050 | PARK MAINTENANCE WORKER III | A17 | WKSTN-O-0064 | O | 64 |
| 001244 | PARK OPERATIONS & PLANNING COORDINATOR | A25 | WKSTN-O-0064 | O | 64 |
| 001243 | PARK OPERATIONS & PLANNING SPECIALIST II | A22 | WKSTN-O-0064 | O | 64 |
| 001242 | PARK OPERATIONS & PLANNING SPECIALIST I | A18 | WKSTN-O-0064 | O | 64 |
| 001270 | PARK RANGER | A23 | WKSTN-O-0064 | O | 64 |
| 001268 | PARK RANGER CORPORAL | A25 | WKSTN-O-0064 | O | 64 |
| 001269 | PARK RANGER RECRUIT | A21 | WKSTN-O-0064 | O | 64 |
| 001271 | PARK RANGER SERGEANT | A27 | WKSTN-O-0096 | O | 96 |
| 001230 | PARK/HISTORIC SITE SPECIALIST I | A18 | WKSTN-O-0064 | O | 64 |
| 001231 | PARK/HISTORIC SITE SPECIALIST II | A22 | WKSTN-O-0064 | O | 64 |
| 001232 | PARK/HISTORIC SITE SPECIALIST III | A24 | WKSTN-O-0064 | O | 64 |
| 005128 | PAROLE HEARING ANALYST | A30 | WKSTN-O-0096 | O | 96 |
| 009733 | PASTORAL COUNSELOR | | WKSTN-O-0096 | O | 96 |
| 009790 | PERSONNEL ANALYST | | WKSTN-O-0064 | O | 64 |
| 000411 | PERSONNEL ANALYST I | A18 | WKSTN-O-0064 | O | 64 |
| 000412 | PERSONNEL ANALYST II | A23 | WKSTN-O-0064 | O | 64 |
| 000413 | PERSONNEL ANALYST III | A28 | WKSTN-O-0096 | O | 96 |
| 000414 | PERSONNEL ANALYST IV | A32 | WKSTN-O-0120 | O | 120 |
| 009791 | PERSONNEL ANALYST SUPERVISOR | | WKSTN-O-0096 | O | 96 |
| 000627 | PERSONNEL CLERK | A15 | WKSTN-O-0064 | O | 64 |
| 009792 | PERSONNEL CONSULTANT | | WKSTN-O-0064 | O | 64 |
| 000401 | PERSONNEL OFFICER I | A25 | WKSTN-O-0064 | O | 64 |
| 000402 | PERSONNEL OFFICER II | A28 | WKSTN-O-0096 | O | 96 |
| 007516 | PESTICIDE USE INVESTIGATOR | A22 | WKSTN-O-0064 | O | 64 |
| 004504 | PHARMACEUTICAL CONSULTANT | A32 | WKSTN-O-0120 | O | 120 |

Statewide Space Standards

Issue Date: July 12, 2007

Proprietary
Version: 1.1.9
Page 17 of 55

| TITLE CODE | CLASS TITLE | GRADE | FUNCTIONAL WORK SPACE CODE | WORK SPACE STANDARD | |
|------------|--|-------|----------------------------|---------------------|-------------------------|
| | | | | PRIVATE/ OPEN | PERSONAL SPACE STANDARD |
| 004501 | PHARMACIST | A29 | WKSTN-O-0096 | O | 96 |
| 004515 | PHARMACY ASSISTANT I | A09 | WKSTN-O-0064 | O | 64 |
| 004516 | PHARMACY ASSISTANT II | A13 | WKSTN-O-0064 | O | 64 |
| 004503 | PHARMACY DIRECTOR | A34 | WKSTN-O-0120 | O | 120 |
| 004502 | PHARMACY SUPERVISOR | A32 | WKSTN-O-0120 | O | 120 |
| 006363 | PHOTOGRAPHER | A15 | WKSTN-O-0064 | O | 64 |
| 000067 | PHOTOGRAPHIC-MACHINE OPERATOR | A09 | WKSTN-O-0048 | O | 48 |
| 004426 | PHYSICAL THERAPIST ASSISTANT | A16 | WKSTN-O-0064 | O | 64 |
| 004431 | PHYSICAL THERAPIST I | A24 | WKSTN-O-0064 | O | 64 |
| 004432 | PHYSICAL THERAPIST II | A27 | WKSTN-O-0096 | O | 96 |
| 004433 | PHYSICAL THERAPIST III | A29 | WKSTN-O-0096 | O | 96 |
| 004429 | PHYSICAL THERAPY AIDE I | A07 | WKSTN-O-0048 | O | 48 |
| 004430 | PHYSICAL THERAPY AIDE II | A10 | WKSTN-O-0048 | O | 48 |
| 004428 | PHYSICAL THERAPY TECHNICIAN | A13 | WKSTN-O-0064 | O | 64 |
| 004274 | PHYSICIAN I | B01 | WKSTN-O-0120 | O | 120 |
| 004275 | PHYSICIAN II | B03 | WKSTN-O-0120 | O | 120 |
| 004276 | PHYSICIAN III | B04 | WKSTN-O-0120 | O | 120 |
| 000556 | PLANNER I | A22 | WKSTN-O-0064 | O | 64 |
| 000557 | PLANNER II | A25 | WKSTN-O-0064 | O | 64 |
| 000558 | PLANNER III | A28 | WKSTN-O-0096 | O | 96 |
| 000559 | PLANNER IV | A32 | WKSTN-O-0120 | O | 120 |
| 007529 | PLANT INDUSTRIES PROGRAM COORDINATOR | A28 | WKSTN-O-0096 | O | 96 |
| 006111 | PLANT MAINTENANCE ENGINEER I | A22 | WKSTN-O-0064 | O | 64 |
| 006112 | PLANT MAINTENANCE ENGINEER II | A24 | WKSTN-O-0064 | O | 64 |
| 006113 | PLANT MAINTENANCE ENGINEER III | A27 | WKSTN-O-0096 | O | 96 |
| 007519 | PLANT PROTECTION SPECIALIST | A24 | WKSTN-O-0064 | O | 64 |
| 006070 | PLUMBER | A17 | WKSTN-O-0048 | O | 48 |
| 006072 | PLUMBER SUPERVISOR | A19 | WKSTN-O-0064 | O | 64 |
| 009868 | POLICYMAKING ASSISTANT - DEPARTMENT LEVEL | | WKSTN-O-0096 | O | 96 |
| 009869 | POLICYMAKING ASSISTANT - DIVISION LEVEL | | WKSTN-O-0064 | O | 64 |
| 006074 | POWER PLANT MECHANIC | A18 | WKSTN-O-0064 | O | 64 |
| 009716 | PRINCIPAL ADMINISTRATIVE ASSISTANT | | WKSTN-O-0064 | O | 64 |
| 009878 | PRINCIPAL ASSISTANT, BOARD/COMMISSION | | WKSTN-O-0120 | O | 120 |
| 000098 | PRINTING / MAIL COORDINATOR | A22 | WKSTN-O-0096 | O | 96 |
| 000097 | PRINTING / MAIL CUSTOMER SERVICE REPRESENTATIVE | A20 | WKSTN-O-0096 | O | 96 |
| 000093 | PRINTING / MAIL TECHNICIAN I | A10 | WKSTN-O-0036 | O | 36*2 |
| 000094 | PRINTING / MAIL TECHNICIAN II | A13 | WKSTN-O-0036 | O | 36*2 |
| 000095 | PRINTING / MAIL TECHNICIAN III | A16 | WKSTN-O-0036 | O | 36 |
| 000096 | PRINTING / MAIL TECHNICIAN IV | A18 | WKSTN-O-0064 | O | 64 |
| 000235 | PRINTING SERVICES ANALYST | A23 | WKSTN-O-0064 | O | 64 |
| 000071 | PRINTING SERVICES ASSISTANT | A06 | WKSTN-O-0048 | O | 48 |
| 000079 | PRINTING SERVICES COORDINATOR | A22 | WKSTN-O-0064 | O | 64 |
| 000072 | PRINTING SERVICES REPRESENTATIVE | A20 | WKSTN-O-0064 | O | 64 |
| 000073 | PRINTING SERVICES TECHNICIAN I | A10 | WKSTN-O-0048 | O | 48 |
| 000074 | PRINTING SERVICES TECHNICIAN II | A13 | WKSTN-O-0064 | O | 64 |
| 000075 | PRINTING SERVICES TECHNICIAN III | A16 | WKSTN-O-0064 | O | 64 |
| 000076 | PRINTING SERVICES TECHNICIAN IV | A18 | WKSTN-O-0064 | O | 64 |
| 005118 | PROBATION & PAROLE ASSISTANT I | A16 | WKSTN-O-0064 | O | 64 |
| 005119 | PROBATION & PAROLE ASSISTANT II | A18 | WKSTN-O-0064 | O | 64 |
| 005117 | PROBATION & PAROLE OFFICER I | A18 | WKSTN-O-0096 | O | 96 |
| 005121 | PROBATION & PAROLE OFFICER II | A21-P | WKSTN-O-0096 | O | 96 |
| 005122 | PROBATION & PAROLE OFFICER III | A23-P | WKSTN-O-0096 | O | 96 |
| 005120 | PROBATION & PAROLE UNIT SUPERVISOR | A26 | WKSTN-P-0120 | P | 120*1 |
| 000236 | PROCUREMENT OFFICER I | A23 | WKSTN-O-0064 | O | 64 |
| 000237 | PROCUREMENT OFFICER II | A28 | WKSTN-O-0096 | O | 96 |
| 006281 | PRODUCTION SPECIALIST I (CORRECTIONS) | A25 | WKSTN-O-0064 | O | 64 |
| 006282 | PRODUCTION SPECIALIST II (CORRECTIONS) | A27 | WKSTN-O-0096 | O | 96 |
| 007870 | PROFESSIONAL REGISTRATION ADMINISTRATIVE COORDINATOR | A24 | WKSTN-O-0064 | O | 64 |
| 007867 | PROFESSIONAL REGISTRATION LICENSING TECHNICIAN I | A12 | WKSTN-O-0064 | O | 64 |
| 007868 | PROFESSIONAL REGISTRATION LICENSING TECHNICIAN II | A14 | WKSTN-O-0064 | O | 64 |
| 007869 | PROFESSIONAL REGISTRATION LICENSING/CERTIFICATION SUPERVISOR | A18 | WKSTN-O-0064 | O | 64 |

| TITLE CODE | CLASS TITLE | GRADE | FUNCTIONAL WORK SPACE CODE | WORK SPACE STANDARD | |
|------------|--|-------|----------------------------|---------------------|-------------------------|
| | | | | PRIVATE/ OPEN | PERSONAL SPACE STANDARD |
| 007880 | PROFESSIONAL REGISTRATION OPERATIONS COORDINATOR | A23 | WKSTN-O-0064 | O | 64 |
| 009728 | PROGRAM CONSULTANT | | WKSTN-O-0064 | O | 64 |
| 004541 | PROGRAM COORDINATOR (MENTAL HEALTH) (HEALTH & SENIOR SERVICES) | A30 | WKSTN-O-0096 | O | 96 |
| 005249 | PROGRAM DEVELOPMENT SPECIALIST | A25 | WKSTN-O-0064 | O | 64 |
| 009725 | PROGRAM MANAGER | | WKSTN-O-0096 | O | 96 |
| 009729 | PROGRAM SPECIALIST | | WKSTN-O-0064 | O | 64 |
| 004544 | PROGRAM SPECIALIST I (MENTAL HEALTH/REHAB SERVICES) | A24 | WKSTN-O-0096 | O | 96 |
| 004539 | PROGRAM SPECIALIST II (MENTAL HEALTH/REHAB SERVICES) | A26 | WKSTN-O-0096 | O | 96 |
| 009727 | PROGRAM SUPERVISOR | | WKSTN-O-0096 | O | 96 |
| 009723 | PROJECT CONSULTANT | | WKSTN-O-0064 | O | 64 |
| 009719 | PROJECT MANAGER | | WKSTN-O-0096 | O | 96 |
| 009724 | PROJECT SPECIALIST | | WKSTN-O-0064 | O | 64 |
| 009721 | PROJECT SUPERVISOR | | WKSTN-O-0096 | O | 96 |
| 009771 | PROPERTY ASSISTANT | | WKSTN-O-0064 | O | 64 |
| 000217 | PROPERTY CONTROL ASSISTANT | A16 | WKSTN-O-0064 | O | 64 |
| 004307 | PSYCHIATRIC AIDE I | A07 | WKSTN-O-0048 | O | 48 |
| 004308 | PSYCHIATRIC AIDE II | A10 | WKSTN-O-0048 | O | 48 |
| 004277 | PSYCHIATRIST I | B10 | WKSTN-O-0120 | O | 120 |
| 004278 | PSYCHIATRIST II | B11 | WKSTN-O-0120 | O | 120 |
| 004402 | PSYCHOLOGIST I | A29 | WKSTN-O-0096 | O | 96 |
| 004403 | PSYCHOLOGIST II | A31 | WKSTN-O-0096 | O | 96 |
| 004376 | PUBLIC HEALTH CONSULTANT NURSE | A31 | WKSTN-O-0096 | O | 96 |
| 000933 | PUBLIC HEALTH EPIDEMIOLOGIST | A32 | WKSTN-O-0120 | O | 120 |
| 004105 | PUBLIC HEALTH LABORATORY SCIENTIST | A23 | WKSTN-O-0064 | O | 64 |
| 004372 | PUBLIC HEALTH NURSE | A26 | WKSTN-O-0064 | O | 64 |
| 004374 | PUBLIC HEALTH SENIOR NURSE | A29 | WKSTN-O-0096 | O | 96 |
| 007556 | PUBLIC INFORMATION & MARKETING COORDINATOR (STATE FAIR) | A28 | WKSTN-O-0096 | O | 96 |
| 000458 | PUBLIC INFORMATION ADMINISTRATOR | A28 | WKSTN-O-0096 | O | 96 |
| 000454 | PUBLIC INFORMATION COORDINATOR | A24 | WKSTN-O-0064 | O | 64 |
| 000451 | PUBLIC INFORMATION SPECIALIST I | A18 | WKSTN-O-0064 | O | 64 |
| 000452 | PUBLIC INFORMATION SPECIALIST II | A21 | WKSTN-O-0064 | O | 64 |
| 008183 | PUBLIC SAFETY MANAGER B1 | 1 | WKSTN-O-0120 | O | 120 |
| 008184 | PUBLIC SAFETY MANAGER B2 | 2 | WKSTN-O-0120 | O | 120 |
| 008185 | PUBLIC SAFETY MANAGER B3 | 3 | WKSTN-O-0120 | O | 120 |
| 008551 | PUBLIC SAFETY PROGRAM REPRESENTATIVE I | A18 | WKSTN-O-0064 | O | 64 |
| 008552 | PUBLIC SAFETY PROGRAM REPRESENTATIVE II | A22 | WKSTN-O-0064 | O | 64 |
| 008553 | PUBLIC SAFETY PROGRAM SPECIALIST | A25 | WKSTN-O-0064 | O | 64 |
| 000836 | PUBLIC UTILITY ACCOUNTANT I | A21 | WKSTN-O-0064 | O | 64 |
| 000837 | PUBLIC UTILITY ACCOUNTANT II | A24 | WKSTN-O-0064 | O | 64 |
| 000839 | PUBLIC UTILITY ACCOUNTANT III | A26 | WKSTN-O-0096 | O | 96 |
| 000845 | PUBLIC UTILITY ENGINEER | A34 | WKSTN-O-0120 | O | 120 |
| 000848 | PUBLIC UTILITY FINANCIAL ANALYST | A25 | WKSTN-O-0064 | O | 64 |
| 009774 | PURCHASING OFFICER | | WKSTN-O-0064 | O | 64 |
| 004597 | QUALITY ASSURANCE SPECIALIST (MENTAL HEALTH) | A25 | WKSTN-O-0064 | O | 64 |
| 006089 | RADIO TECHNICIAN | A24 | WKSTN-O-0064 | O | 64 |
| 007222 | RADIO/TELECOMMUNICATIONS COORDINATOR | A22 | WKSTN-O-0064 | O | 64 |
| 007220 | RADIO/TELECOMMUNICATIONS OFFICER | A18 | WKSTN-O-0064 | O | 64 |
| 007221 | RADIO/TELECOMMUNICATIONS SUPERVISOR | A20 | WKSTN-O-0064 | O | 64 |
| 007324 | RADIOLOGICAL DEFENSE OFFICER | A28 | WKSTN-O-0096 | O | 96 |
| 007335 | RADIOLOGICAL EMERGENCY PLANNER | A27 | WKSTN-O-0096 | O | 96 |
| 007323 | RADIOLOGICAL SYSTEMS MAINTENANCE SUPERVISOR | A23 | WKSTN-O-0064 | O | 64 |
| 007322 | RADIOLOGICAL SYSTEMS MAINTENANCE TECHNICIAN | A18 | WKSTN-O-0064 | O | 64 |
| 007843 | RATE & TARIFF EXAMINATION SUPERVISOR | A32 | WKSTN-O-0120 | O | 120 |
| 007840 | RATE & TARIFF EXAMINER I | A22 | WKSTN-O-0064 | O | 64 |
| 007841 | RATE & TARIFF EXAMINER II | A25 | WKSTN-O-0064 | O | 64 |
| 007842 | RATE & TARIFF EXAMINER III | A28 | WKSTN-O-0096 | O | 96 |
| 007875 | REAL ESTATE EDUCATION SPECIALIST | A18 | WKSTN-O-0064 | O | 64 |
| 007871 | REAL ESTATE EXAMINER I | A18 | WKSTN-O-0064 | O | 64 |
| 007872 | REAL ESTATE EXAMINER II | A23 | WKSTN-O-0064 | O | 64 |
| 007873 | REAL ESTATE EXAMINER SUPERVISOR | A26 | WKSTN-O-0096 | O | 96 |

| TITLE CODE | CLASS TITLE | GRADE | FUNCTIONAL WORK SPACE CODE | WORK SPACE STANDARD | |
|------------|---|-------|----------------------------|---------------------|-------------------------|
| | | | | PRIVATE/ OPEN | PERSONAL SPACE STANDARD |
| 009757 | RECEPTIONIST | | WKSTN-O-0064 | O | 64 |
| 005026 | RECREATION OFFICER I | A17 | WKSTN-O-0064 | O | 64 |
| 005027 | RECREATION OFFICER II | A19 | WKSTN-O-0064 | O | 64 |
| 005028 | RECREATION OFFICER III | A23 | WKSTN-O-0064 | O | 64 |
| 004463 | RECREATIONAL THERAPIST I | A19 | WKSTN-O-0064 | O | 64 |
| 004464 | RECREATIONAL THERAPIST II | A22 | WKSTN-O-0064 | O | 64 |
| 004465 | RECREATIONAL THERAPIST III | A24 | WKSTN-O-0064 | O | 64 |
| 006035 | REFRIGERATION MECHANIC I | A18 | WKSTN-O-0064 | O | 64 |
| 006036 | REFRIGERATION MECHANIC II | A20 | WKSTN-O-0064 | O | 64 |
| 005233 | REGIONAL CONSULTANT-RESIDENTIAL LICENSING UNIT | A26 | WKSTN-O-0096 | O | 96 |
| 005082 | REGIONAL FAMILY SPECIALIST | A23 | WKSTN-O-0064 | O | 64 |
| 160695 | REGIONAL MANAGER - BROADBAND I | A28 | OFFICE-P-120 | P | 120*1 |
| 004590 | REGIONAL PROGRAM SPECIALIST (DEVELOP DISABIL) | A26 | WKSTN-O-0096 | O | 96 |
| 004320 | REGISTERED NURSE I | A22 | WKSTN-O-0064 | O | 64 |
| 004321 | REGISTERED NURSE II | A24 | WKSTN-O-0064 | O | 64 |
| 004322 | REGISTERED NURSE III | A27 | WKSTN-O-0064 | O | 64 |
| 004323 | REGISTERED NURSE IV | A29 | WKSTN-O-0096 | O | 96 |
| 004324 | REGISTERED NURSE V | A30 | WKSTN-O-0096 | O | 96 |
| 004325 | REGISTERED NURSE VI | A32 | WKSTN-O-0096 | O | 96 |
| 004326 | REGISTERED NURSE VII | A34 | WKSTN-O-0120 | O | 120 |
| 007810 | REGULATORY ECONOMIST I | A25 | WKSTN-O-0064 | O | 64 |
| 007811 | REGULATORY ECONOMIST II | A28 | WKSTN-O-0096 | O | 96 |
| 007812 | REGULATORY ECONOMIST III | A32 | WKSTN-O-0120 | O | 120 |
| 009738 | REGULATORY LAW JUDGE | | OFFICE-P-0120 | P | 120*1 |
| 005165 | REHABILITATION ASSISTANT (REHAB SRVS FOR THE BLIND) | A13 | WKSTN-O-0064 | O | 64 |
| 005167 | REHABILITATION COUNSELOR FOR THE BLIND II | A22 | WKSTN-O-0096 | O | 96 |
| 005151 | REHABILITATION TEACHER FOR THE BLIND | A21 | WKSTN-O-0064 | O | 64 |
| 000623 | REIMBURSEMENT OFFICER I | A17 | WKSTN-O-0064 | O | 64 |
| 000624 | REIMBURSEMENT OFFICER II | A20 | WKSTN-O-0064 | O | 64 |
| 000625 | REIMBURSEMENT OFFICER III | A22 | WKSTN-O-0064 | O | 64 |
| 000431 | RESEARCH ANALYST I | A18 | WKSTN-O-0064 | O | 64 |
| 000432 | RESEARCH ANALYST II | A22 | WKSTN-O-0064 | O | 64 |
| 000433 | RESEARCH ANALYST III | A25 | WKSTN-O-0064 | O | 64 |
| 000434 | RESEARCH ANALYST IV | A28 | WKSTN-O-0096 | O | 96 |
| 009795 | RESEARCH CONSULTANT | | WKSTN-O-0064 | O | 64 |
| 008073 | RESEARCH MANAGER B1 | 1 | WKSTN-O-0120 | O | 120 |
| 008074 | RESEARCH MANAGER B2 | 2 | WKSTN-O-0120 | O | 120 |
| 008075 | RESEARCH MANAGER B3 | 3 | WKSTN-O-0120 | O | 120 |
| 009793 | RESEARCH WORKER | | WKSTN-O-0064 | O | 64 |
| 009862 | RESIDENT PHYSICIAN | | WKSTN-O-0120 | O | 120 |
| 007627 | REVENUE FIELD SERVICES COORDINATOR | A22 | WKSTN-O-0064 | O | 64 |
| 007626 | REVENUE FIELD SERVICES REPRESENTATIVE | A19 | WKSTN-O-0064 | O | 64 |
| 007631 | REVENUE LICENSING TECHNICIAN I | A10 | WKSTN-O-0048 | O | 48 |
| 007632 | REVENUE LICENSING TECHNICIAN II | A13 | WKSTN-O-0048 | O | 48 |
| 007615 | REVENUE LICENSING UNIT SUPERVISOR | A16 | WKSTN-O-0064 | O | 64 |
| 008192 | REVENUE MANAGER B1 | 1 | WKSTN-O-0120 | O | 120 |
| 008193 | REVENUE MANAGER B2 | 2 | WKSTN-O-0120 | O | 120 |
| 008194 | REVENUE MANAGER B3 | 3 | WKSTN-O-0120 | O | 120 |
| 007616 | REVENUE SECTION SUPERVISOR | A22 | WKSTN-O-0096 | O | 96 |
| 000520 | RISK MANAGEMENT SPECIALIST I | A25 | WKSTN-O-0064 | O | 64 |
| 000523 | RISK MANAGEMENT SPECIALIST II | A28 | WKSTN-O-0096 | O | 96 |
| 000518 | RISK MANAGEMENT TECHNICIAN I | A14 | WKSTN-O-0064 | O | 64 |
| 000519 | RISK MANAGEMENT TECHNICIAN II | A18 | WKSTN-O-0064 | O | 64 |
| 006380 | SATELLITE BROADCAST & VIDEO PRODUCER | A26 | WKSTN-O-0096 | O | 96 |
| 009833 | SEAMSTRESS | | WKSTN-O-0048 | O | 48 |
| 009823 | SEASONAL AIDE | | WKSTN-O-0048 | O | 48 |
| 009824 | SEASONAL NATURALIST | | WKSTN-O-0064 | O | 64 |
| 009751 | SECRETARY | | WKSTN-O-0064 | O | 64 |
| 000190 | SECTION MANAGER (DIVISION OF INFORMATION SERVICES) | A35 | WKSTN-O-0120 | O | 120 |
| 004303 | SECURITY AIDE I (PSYCHIATRIC) | A16 | WKSTN-O-0064 | O | 64 |
| 004304 | SECURITY AIDE II (PSYCHIATRIC) | A18 | WKSTN-O-0064 | O | 64 |
| 004305 | SECURITY AIDE III (PSYCHIATRIC) | A21 | WKSTN-O-0064 | O | 64 |

Statewide Space Standards

Issue Date: July 12, 2007

Proprietary
Version: 1.1.9
Page 20 of 55

| TITLE CODE | CLASS TITLE | GRADE | FUNCTIONAL WORK SPACE CODE | WORK SPACE STANDARD | |
|------------|--|-------|----------------------------|---------------------|-------------------------|
| | | | | PRIVATE/ OPEN | PERSONAL SPACE STANDARD |
| 004302 | SECURITY ATTENDANT | A15 | WKSTN-O-0064 | O | 64 |
| 002042 | SECURITY GUARD | A08 | WKSTN-O-0048 | O | 48 |
| 000655 | SECURITY OFFICER I | A12 | WKSTN-O-0064 | O | 64 |
| 000656 | SECURITY OFFICER II | A14 | WKSTN-O-0064 | O | 64 |
| 000657 | SECURITY OFFICER III | A16 | WKSTN-O-0064 | O | 64 |
| 007496 | SEED ANALYST I | A12 | WKSTN-O-0064 | O | 64 |
| 007497 | SEED ANALYST II | A17 | WKSTN-O-0064 | O | 64 |
| 007498 | SEED ANALYST III | A20 | WKSTN-O-0064 | O | 64 |
| 007495 | SEED ANALYST TRAINEE | A08 | WKSTN-O-0048 | O | 48 |
| 005206 | SELF-SUFFICIENCY CASE MANAGER | A19 | WKSTN-O-0064 | O | 64 |
| 000306 | SENIOR AUDITOR | A26 | WKSTN-O-0096 | O | 96 |
| 009748 | SENIOR COUNSEL | | OFFICE-P-0120 | P | 120* ¹ |
| 000931 | SENIOR EPIDEMIOLOGY SPECIALIST | A28 | WKSTN-O-0096 | O | 96 |
| 000671 | SENIOR HOUSING DEVELOPMENT OFFICER | A23 | WKSTN-O-0064 | O | 64 |
| 000686 | SENIOR HOUSING PROGRAM AUDITOR & INSPECTOR | A29 | WKSTN-O-0096 | O | 96 |
| 000003 | SENIOR OFFICE SUPPORT ASSISTANT (CLERICAL) | A12 | WKSTN-O-0064 | O | 64 |
| 000023 | SENIOR OFFICE SUPPORT ASSISTANT (KEYBRD) | A12 | WKSTN-O-0064 | O | 64 |
| 000013 | SENIOR OFFICE SUPPORT ASSISTANT (STENO) | A13 | WKSTN-O-0064 | O | 64 |
| 004279 | SENIOR PSYCHIATRIST | B12 | WKSTN-O-0120 | O | 120 |
| 004106 | SENIOR PUBLIC HEALTH LABORATORY SCIENTIST | A26 | WKSTN-O-0096 | O | 96 |
| 005173 | SENIOR VOCATIONAL REHABILITATION COUNSELOR FOR THE BLIND | A24 | WKSTN-O-0120 | O | 120 |
| 005085 | SERVICE COORDINATION SUPERVISOR (YOUTH SERVICES) | A25 | WKSTN-O-0096 | O | 96 |
| 005083 | SERVICE COORDINATOR (YOUTH SERVICES) | A20 | WKSTN-O-0064 | O | 64 |
| 005084 | SERVICE COORDINATOR II (YOUTH SERVICES) | A23 | WKSTN-O-0064 | O | 64 |
| 006219 | SERVICE MANAGER I | A21 | WKSTN-O-0064 | O | 64 |
| 006220 | SERVICE MANAGER II | A24 | WKSTN-O-0064 | O | 64 |
| 006080 | SHEET METAL WORKER | A17 | WKSTN-O-0064 | O | 64 |
| 006394 | SIGN MAKER I | A12 | WKSTN-O-0064 | O | 64 |
| 006395 | SIGN MAKER II | A16 | WKSTN-O-0064 | O | 64 |
| 005199 | SOCIAL SERVICE WORKER I | A18 | WKSTN-O-0064 | O | 64 |
| 005200 | SOCIAL SERVICE WORKER II | A20 | WKSTN-O-0064 | O | 64 |
| 008201 | SOCIAL SERVICES MANAGER B1 | 1 | WKSTN-O-0120 | O | 120 |
| 008202 | SOCIAL SERVICES MANAGER B2 | 2 | WKSTN-O-0120 | O | 120 |
| 008203 | SOCIAL SERVICES MANAGER B3 | 3 | WKSTN-O-0120 | O | 120 |
| 004780 | SOIL SCIENTIST I | A18 | WKSTN-O-0064 | O | 64 |
| 004781 | SOIL SCIENTIST II | A22 | WKSTN-O-0064 | O | 64 |
| 004782 | SOIL SCIENTIST III | A25 | WKSTN-O-0064 | O | 64 |
| 004783 | SOIL SCIENTIST IV | A28 | WKSTN-O-0096 | O | 96 |
| 008562 | SPECIAL AGENT (LIQUOR CONTROL) | A25 | WKSTN-O-0064 | O | 64 |
| 009875 | SPECIAL ASSISTANT - OFFICE AND CLERICAL | | WKSTN-O-0064 | O | 64 |
| 009870 | SPECIAL ASSISTANT - OFFICIAL AND ADMINISTRATOR | | WKSTN-O-0064 | O | 64 |
| 009874 | SPECIAL ASSISTANT - PARAPROFESSIONAL | | WKSTN-O-0064 | O | 64 |
| 009871 | SPECIAL ASSISTANT - PROFESSIONAL | | WKSTN-O-0064 | O | 64 |
| 009873 | SPECIAL ASSISTANT - PROTECTIVE SERVICE WORKER | | WKSTN-O-0064 | O | 64 |
| 039877 | SPECIAL ASSISTANT - SERVICE MAINTENANCE | | WKSTN-O-0064 | O | 64 |
| 009876 | SPECIAL ASSISTANT - SKILLED CRAFT WORKER | | WKSTN-O-0064 | O | 64 |
| 009872 | SPECIAL ASSISTANT - TECHNICIAN | | WKSTN-O-0064 | O | 64 |
| 003045 | SPECIAL EDUCATION TEACHER I | A18 | WKSTN-O-0064 | O | 64 |
| 003046 | SPECIAL EDUCATION TEACHER II | A22 | WKSTN-O-0064 | O | 64 |
| 003047 | SPECIAL EDUCATION TEACHER III | A24 | WKSTN-O-0064 | O | 64 |
| 000920 | SPECIAL HEALTH CARE NEEDS REGIONAL COORDINATOR | A28 | WKSTN-O-0096 | O | 96 |
| 004466 | SPEECH-LANGUAGE PATHOLOGIST | A24 | WKSTN-O-0064 | O | 64 |
| 004471 | SPEECH-LANGUAGE PATHOLOGY ASSISTANT I | A18 | WKSTN-O-0064 | O | 64 |
| 004472 | SPEECH-LANGUAGE PATHOLOGY ASSISTANT II | A20 | WKSTN-O-0064 | O | 64 |
| 004596 | STAFF DEVELOPMENT OFFICER (MENTAL HEALTH) | A26 | WKSTN-O-0096 | O | 96 |
| 009712 | STAFF DIRECTOR | | OFFICE-P-0120 | P | 120* ¹ |
| 009863 | STAFF PHYSICIAN | | WKSTN-O-0120 | O | 120 |
| 009864 | STAFF PHYSICIAN SPECIALIST | | WKSTN-O-0120 | O | 120 |
| 000490 | STAFF TRAINING & DEVELOPMENT COORDINATOR | A29 | WKSTN-O-0096 | O | 96 |
| 005197 | STATE CONSULTANT ON CHILD WELFARE | A25 | WKSTN-O-0064 | O | 64 |
| 000468 | STATE DEMOGRAPHER | A33 | WKSTN-O-0120 | O | 120 |

Statewide Space Standards

Issue Date: July 12, 2007

Proprietary
Version: 1.1.9
Page 21 of 55

| TITLE CODE | CLASS TITLE | GRADE | FUNCTIONAL WORK SPACE CODE | WORK SPACE STANDARD | |
|------------|---|-------|----------------------------|---------------------|-------------------------|
| | | | | PRIVATE/ OPEN | PERSONAL SPACE STANDARD |
| 009700 | STATE DEPARTMENT DIRECTOR | | OFFICE-P-0240 | P | 240* |
| 007555 | STATE FAIR EVENTS/CONCESSIONS COORDINATOR | A26 | WKSTN-O-0064 | O | 64 |
| 007350 | STATE HAZARD MITIGATION OFFICER | A28 | WKSTN-O-0096 | O | 96 |
| 000261 | STATE LEASING COORDINATOR | A28 | WKSTN-O-0096 | O | 96 |
| 007360 | STATE VETERANS CEMETERY WORKER | A11 | WKSTN-O-0064 | O | 64 |
| 007349 | STATEWIDE VOLUNTEER COORDINATOR (SEMA) | A29 | WKSTN-O-0096 | O | 96 |
| 006103 | STATIONARY ENGINEER | A20 | WKSTN-O-0064 | O | 64 |
| 009770 | STOREKEEPER | | WKSTN-O-0064 | O | 64 |
| 000202 | STOREKEEPER I | A12 | WKSTN-O-0064 | O | 64 |
| 000204 | STOREKEEPER II | A15 | WKSTN-O-0064 | O | 64 |
| 000201 | STORES CLERK | A07 | WKSTN-O-0048 | O | 48 |
| 009743 | STUDENT INTERN | | WKSTN-O-0036 | O | 36 |
| 009745 | STUDENT WORKER | | WKSTN-O-0036 | O | 36 |
| 004491 | SUBSTANCE ABUSE COUNSELOR ASSISTANT I | A12 | WKSTN-O-0096 | O | 96 |
| 004492 | SUBSTANCE ABUSE COUNSELOR ASSISTANT II | A15 | WKSTN-O-0096 | O | 96 |
| 004493 | SUBSTANCE ABUSE COUNSELOR I | A18 | WKSTN-O-0096 | O | 96 |
| 004494 | SUBSTANCE ABUSE COUNSELOR II | A21 | WKSTN-O-0096 | O | 96 |
| 004495 | SUBSTANCE ABUSE COUNSELOR III | A23 | WKSTN-O-0096 | O | 96 |
| 004496 | SUBSTANCE ABUSE UNIT SUPERVISOR | A26 | WKSTN-O-0096 | O | 96 |
| 000581 | SUPERVISOR OF VOLUNTEER SERVICES | A16 | WKSTN-O-0064 | O | 64 |
| 000205 | SUPPLY MANAGER I | A19 | WKSTN-O-0064 | O | 64 |
| 000206 | SUPPLY MANAGER II | A21 | WKSTN-O-0064 | O | 64 |
| 007650 | TAX AUDIT REVIEW SPECIALIST | A30 | WKSTN-O-0096 | O | 96 |
| 007654 | TAX AUDIT SUPERVISOR | A29 | WKSTN-O-0096 | O | 96 |
| 007651 | TAX AUDITOR I | A21 | WKSTN-O-0064 | O | 64 |
| 007652 | TAX AUDITOR II | A24 | WKSTN-O-0064 | O | 64 |
| 007653 | TAX AUDITOR III | A26 | WKSTN-O-0096 | O | 96 |
| 007606 | TAX COLLECTION TECHNICIAN I | A10 | WKSTN-O-0064 | O | 64 |
| 007607 | TAX COLLECTION TECHNICIAN II | A13 | WKSTN-O-0064 | O | 64 |
| 007608 | TAX COLLECTION TECHNICIAN III | A16 | WKSTN-O-0064 | O | 64 |
| 008207 | TAX COMMISSION MANAGER B1 | 1 | WKSTN-O-0120 | O | 120 |
| 008208 | TAX COMMISSION MANAGER B2 | 2 | WKSTN-O-0120 | O | 120 |
| 008209 | TAX COMMISSION MANAGER B3 | 3 | WKSTN-O-0120 | O | 120 |
| 007601 | TAX PROCESSING TECHNICIAN I | A10 | WKSTN-O-0064 | O | 64 |
| 007602 | TAX PROCESSING TECHNICIAN II | A13 | WKSTN-O-0064 | O | 64 |
| 007603 | TAX PROCESSING TECHNICIAN III | A16 | WKSTN-O-0064 | O | 64 |
| 007604 | TAX PROCESSING TECHNICIAN IV | A19 | WKSTN-O-0064 | O | 64 |
| 009758 | TAX SEASON ASSISTANT | | WKSTN-O-0064 | O | 64 |
| 007614 | TAXPAYER SERVICES OFFICE MANAGER | A25 | WKSTN-O-0096 | O | 96 |
| 007610 | TAXPAYER SERVICES REPRESENTATIVE I | A14 | WKSTN-O-0064 | O | 64 |
| 007611 | TAXPAYER SERVICES REPRESENTATIVE II | A17 | WKSTN-O-0064 | O | 64 |
| 007613 | TAXPAYER SERVICES SUPERVISOR | A22 | WKSTN-O-0064 | O | 64 |
| 009838 | TEACHER | | WKSTN-O-0064 | O | 64 |
| 004716 | TECHNICAL ASSISTANT I | A11 | WKSTN-O-0064 | O | 64 |
| 004717 | TECHNICAL ASSISTANT II | A14 | WKSTN-O-0064 | O | 64 |
| 004718 | TECHNICAL ASSISTANT III | A18 | WKSTN-O-0064 | O | 64 |
| 004719 | TECHNICAL ASSISTANT IV | A21 | WKSTN-O-0064 | O | 64 |
| 000693 | TELECOMMUNICATIONS ANALYST I | A20 | WKSTN-O-0064 | O | 64 |
| 000694 | TELECOMMUNICATIONS ANALYST II | A23 | WKSTN-O-0064 | O | 64 |
| 000695 | TELECOMMUNICATIONS ANALYST III | A26 | WKSTN-O-0096 | O | 96 |
| 000696 | TELECOMMUNICATIONS ANALYST IV | A30 | WKSTN-O-0096 | O | 96 |
| 000691 | TELECOMMUNICATIONS TECHNICIAN I | A17 | WKSTN-O-0064 | O | 64 |
| 000692 | TELECOMMUNICATIONS TECHNICIAN II | A21 | WKSTN-O-0064 | O | 64 |
| 007621 | TELEPHONE INFORMATION OPERATOR I (REVENUE) | A10 | WKSTN-O-0048 | O | 48 |
| 007622 | TELEPHONE INFORMATION OPERATOR II (REVENUE) | A13 | WKSTN-O-0048 | O | 48 |
| 000482 | TOURIST ASSISTANT | A10 | WKSTN-O-0048 | O | 48 |
| 000483 | TOURIST CENTER SUPERVISOR | A18 | WKSTN-O-0064 | O | 64 |
| 000481 | TOURIST GUIDE | A07 | WKSTN-O-0048 | O | 48 |
| 004566 | TOXICOLOGIST | A32 | WKSTN-O-0120 | O | 120 |
| 006023 | TRACTOR TRAILER DRIVER | A18 | WKSTN-O-0064 | O | 64 |
| 009744 | TRAINEE | | WKSTN-O-0036 | O | 36 |
| 009800 | TRAINING CONSULTANT | | WKSTN-O-0064 | O | 64 |

| TITLE CODE | CLASS TITLE | GRADE | FUNCTIONAL WORK SPACE CODE | WORK SPACE STANDARD | |
|------------|--|-------|----------------------------|---------------------|-------------------------|
| | | | | PRIVATE/ OPEN | PERSONAL SPACE STANDARD |
| 009799 | TRAINING SPECIALIST | | WKSTN-O-0064 | O | 64 |
| 000491 | TRAINING TECHNICIAN I | A22 | WKSTN-O-0064 | O | 64 |
| 000492 | TRAINING TECHNICIAN II | A25 | WKSTN-O-0064 | O | 64 |
| 000493 | TRAINING TECHNICIAN III | A28 | WKSTN-O-0096 | O | 96 |
| 009753 | TYPIST | | WKSTN-O-0048 | O | 48 |
| 000714 | UNEMPLOYMENT INSURANCE AUDITOR I | A19 | WKSTN-O-0064 | O | 64 |
| 000715 | UNEMPLOYMENT INSURANCE AUDITOR II | A21 | WKSTN-O-0064 | O | 64 |
| 000716 | UNEMPLOYMENT INSURANCE AUDITOR III | A24 | WKSTN-O-0064 | O | 64 |
| 004545 | UNIT PROGRAM SUPERVISOR (MENTAL HEALTH) | A24 | WKSTN-O-0096 | O | 96 |
| 000610 | UNIT SUPERVISOR-MERIT SYSTEM (CRS) (TRNS) | A24 | WKSTN-O-0096 | O | 96 |
| 007825 | UTILITY ENGINEERING SPECIALIST I | A28 | WKSTN-O-0096 | O | 96 |
| 007826 | UTILITY ENGINEERING SPECIALIST II | A30 | WKSTN-O-0096 | O | 96 |
| 007827 | UTILITY ENGINEERING SPECIALIST III | A32 | WKSTN-O-0120 | O | 120 |
| 007815 | UTILITY MANAGEMENT ANALYST I | A18 | WKSTN-O-0064 | O | 64 |
| 007816 | UTILITY MANAGEMENT ANALYST II | A23 | WKSTN-O-0064 | O | 64 |
| 007817 | UTILITY MANAGEMENT ANALYST III | A28 | WKSTN-O-0096 | O | 96 |
| 007835 | UTILITY OPERATIONS TECHNICAL SPECIALIST I | A24 | WKSTN-O-0064 | O | 64 |
| 007836 | UTILITY OPERATIONS TECHNICAL SPECIALIST II | A26 | WKSTN-O-0096 | O | 96 |
| 007837 | UTILITY OPERATIONS TECHNICAL SUPERVISOR | A28 | WKSTN-O-0096 | O | 96 |
| 007820 | UTILITY POLICY ANALYST I | A28 | WKSTN-O-0096 | O | 96 |
| 007821 | UTILITY POLICY ANALYST II | A32 | WKSTN-O-0120 | O | 120 |
| 007800 | UTILITY REGULATORY AUDITOR I | A21 | WKSTN-O-0064 | O | 64 |
| 007801 | UTILITY REGULATORY AUDITOR II | A24 | WKSTN-O-0064 | O | 64 |
| 007802 | UTILITY REGULATORY AUDITOR III | A26 | WKSTN-O-0096 | O | 96 |
| 007803 | UTILITY REGULATORY AUDITOR IV | A29 | WKSTN-O-0096 | O | 96 |
| 007804 | UTILITY REGULATORY AUDITOR V | A32 | WKSTN-O-0120 | O | 120 |
| 007828 | UTILITY REGULATORY ENGINEER I | A32 | WKSTN-O-0120 | O | 120 |
| 007829 | UTILITY REGULATORY ENGINEER II | A34 | WKSTN-O-0120 | O | 120 |
| 007830 | UTILITY REGULATORY ENGINEERING SUPERVISOR | A35 | OFFICE-P-0120 | P | 120* ¹ |
| 008210 | UTILITY REGULATORY MANAGER B1 | 1 | WKSTN-O-0120 | O | 120 |
| 008211 | UTILITY REGULATORY MANAGER B2 | 2 | WKSTN-O-0120 | O | 120 |
| 008212 | UTILITY REGULATORY MANAGER B3 | 3 | WKSTN-O-0120 | O | 120 |
| 004548 | VENDOR SERVICES COORDINATOR (MENTAL HEALTH) | A23 | WKSTN-O-0064 | O | 64 |
| 005387 | VETERANS BENEFITS CLAIMS REPRESENTATIVE | A19 | WKSTN-O-0064 | O | 64 |
| 005385 | VETERANS SERVICE ASSISTANT | A16 | WKSTN-O-0064 | O | 64 |
| 005380 | VETERANS SERVICE OFFICER | A17 | WKSTN-O-0096 | O | 96 |
| 005383 | VETERANS SERVICE SUPERVISOR | A22 | WKSTN-O-0096 | O | 96 |
| 007548 | VETERINARIAN I | A30 | WKSTN-O-0096 | O | 96 |
| 007549 | VETERINARIAN II | A32 | WKSTN-O-0120 | O | 120 |
| 007551 | VETERINARY EPIDEMIOLOGIST | A35 | OFFICE-P-0120 | P | 120* ¹ |
| 007550 | VETERINARY LABORATORY MANAGER | A32 | WKSTN-O-0120 | O | 120 |
| 006376 | VIDEO PRODUCTION SPECIALIST I | A18 | WKSTN-O-0064 | O | 64 |
| 006377 | VIDEO PRODUCTION SPECIALIST II | A22 | WKSTN-O-0064 | O | 64 |
| 003017 | VOCATIONAL EDUCATION SUPERVISOR | A26 | WKSTN-O-0096 | O | 96 |
| 006289 | VOCATIONAL ENTERPRISES ANALYST | A27 | WKSTN-O-0096 | O | 96 |
| 006285 | VOCATIONAL ENTERPRISES DISTRIBUTION SUPERVISOR | A22 | WKSTN-O-0064 | O | 64 |
| 006222 | VOCATIONAL ENTERPRISES JOBS COORDINATOR | A21 | WKSTN-O-0064 | O | 64 |
| 006286 | VOCATIONAL ENTERPRISES MARKETING COORDINATOR | A27 | WKSTN-O-0096 | O | 96 |
| 006287 | VOCATIONAL ENTERPRISES REPRESENTATIVE | A20 | WKSTN-O-0064 | O | 64 |
| 006288 | VOCATIONAL ENTERPRISES SALES MANAGER | A24 | WKSTN-O-0064 | O | 64 |
| 006214 | VOCATIONAL ENTERPRISES SUPERVISOR I | A15 | WKSTN-O-0064 | O | 64 |
| 006215 | VOCATIONAL ENTERPRISES SUPERVISOR II | A17 | WKSTN-O-0064 | O | 64 |
| ZZ0006 | VOCATIONAL REHABILITATION COUNSELOR / SR COUNSELOR | | OFFICE-P-0120 | O | 120* ¹ |
| 005172 | VOCATIONAL REHABILITATION COUNSELOR FOR THE BLIND | A22 | WKSTN-P-0120 | P | 120* ¹ |
| 004412 | VOCATIONAL REHABILITATION SPECIALIST I | A20 | WKSTN-O-0064 | O | 64 |
| 004413 | VOCATIONAL REHABILITATION SPECIALIST II | A23 | WKSTN-O-0064 | O | 64 |
| 003070 | VOCATIONAL TEACHER I | A18 | WKSTN-O-0064 | O | 64 |
| 003071 | VOCATIONAL TEACHER II | A21 | WKSTN-O-0064 | O | 64 |
| 003072 | VOCATIONAL TEACHER III | A23 | WKSTN-O-0064 | O | 64 |
| ZZ0007 | VR DISTRICT SUPERVISOR | | OFFICE-P-0120 | O | 120* ¹ |
| 000888 | WAGE AND HOUR INVESTIGATOR I | A18 | WKSTN-O-0064 | O | 64 |
| 000889 | WAGE AND HOUR INVESTIGATOR II | A23 | WKSTN-O-0064 | O | 64 |

Statewide Space Standards

Issue Date: July 12, 2007

Proprietary
Version: 1.1.9
Page 23 of 55

| TITLE CODE | CLASS TITLE | GRADE | FUNCTIONAL WORK SPACE CODE | WORK SPACE STANDARD | |
|------------|---|-------|----------------------------|---------------------|-------------------------|
| | | | | PRIVATE/ OPEN | PERSONAL SPACE STANDARD |
| 000890 | WAGE AND HOUR INVESTIGATOR III | A25 | WKSTN-O-0064 | O | 64 |
| 007214 | WATER PATROL CORPORAL | A26 | WKSTN-O-0064 | O | 64 |
| 007218 | WATER PATROL LIEUTENANT | A29 | WKSTN-O-0120 | O | 120 |
| 007212 | WATER PATROL OFFICER | A24 | WKSTN-O-0064 | O | 64 |
| 007210 | WATER PATROL RECRUIT | A22 | WKSTN-O-0064 | O | 64 |
| 007216 | WATER PATROL SERGEANT | A28 | WKSTN-O-0096 | O | 96 |
| 004645 | WATER SPECIALIST I | A20 | WKSTN-O-0064 | O | 64 |
| 004646 | WATER SPECIALIST II | A23 | WKSTN-O-0064 | O | 64 |
| 004647 | WATER SPECIALIST III | A25 | WKSTN-O-0064 | O | 64 |
| 007537 | WEIGHTS AND MEASURES INSPECTOR I | A17 | WKSTN-O-0064 | O | 64 |
| 007538 | WEIGHTS AND MEASURES INSPECTOR II | A19 | WKSTN-O-0064 | O | 64 |
| 004411 | WORK ADJUSTMENT TRAINING SUPERVISOR | A14 | WKSTN-O-0064 | O | 64 |
| 004435 | WORK THERAPY SPECIALIST I | A11 | WKSTN-O-0064 | O | 64 |
| 004436 | WORK THERAPY SPECIALIST II | A15 | WKSTN-O-0064 | O | 64 |
| 009825 | WORKER (FARM, DAIRY & GROUNDS) | | WKSTN-O-0048 | O | 48 |
| 000881 | WORKERS' COMPENSATION SAFETY CONSULTANT I | A21 | WKSTN-O-0064 | O | 64 |
| 000882 | WORKERS' COMPENSATION SAFETY CONSULTANT II | A25 | WKSTN-O-0064 | O | 64 |
| 007580 | WORKERS' COMPENSATION SPECIALIST | A24 | WKSTN-O-0064 | O | 64 |
| 000601 | WORKERS' COMPENSATION TECHNICIAN I | A12 | WKSTN-O-0064 | O | 64 |
| 000602 | WORKERS' COMPENSATION TECHNICIAN II | A14 | WKSTN-O-0064 | O | 64 |
| 000603 | WORKERS' COMPENSATION TECHNICIAN SUPERVISOR | A18 | WKSTN-O-0096 | O | 96 |
| 000600 | WORKERS' COMPENSATION TRAINEE | A10 | WKSTN-O-0048 | O | 48 |
| 007925 | WORKFORCE DEVELOPMENT DEPUTY | A14 | WKSTN-O-0064 | O | 64 |
| 007928 | WORKFORCE DEVELOPMENT SPECIALIST I | A17 | WKSTN-O-0064 | O | 64 |
| 007929 | WORKFORCE DEVELOPMENT SPECIALIST II | A19 | WKSTN-O-0064 | O | 64 |
| 007930 | WORKFORCE DEVELOPMENT SPECIALIST III | A23 | WKSTN-O-0064 | O | 64 |
| 007931 | WORKFORCE DEVELOPMENT SPECIALIST IV | A27 | WKSTN-O-0096 | O | 96 |
| 007934 | WORKFORCE DEVELOPMENT SUPERVISOR I | A20 | WKSTN-O-0096 | O | 96 |
| 007935 | WORKFORCE DEVELOPMENT SUPERVISOR II | A22 | WKSTN-O-0096 | O | 96 |
| 007936 | WORKFORCE DEVELOPMENT SUPERVISOR III | A24 | WKSTN-O-0096 | O | 96 |
| 004444 | WORKSHOP PROGRAM COORDINATOR | A23 | WKSTN-O-0064 | O | 64 |
| 004437 | WORKSHOP SUPERVISOR I | A10 | WKSTN-O-0048 | O | 48 |
| 004438 | WORKSHOP SUPERVISOR II | A13 | WKSTN-O-0048 | O | 48 |
| 005045 | YOUTH FACILITY MANAGER I | A24 | WKSTN-O-0096 | O | 96 |
| 005046 | YOUTH FACILITY MANAGER II | A25 | WKSTN-O-0096 | O | 96 |
| 005079 | YOUTH GROUP LEADER | A20 | WKSTN-O-0064 | O | 64 |
| 005076 | YOUTH SPECIALIST I | A15 | WKSTN-O-0064 | O | 64 |
| 005077 | YOUTH SPECIALIST II | A18 | WKSTN-O-0064 | O | 64 |

Note: *1 - Square footage subject to change based on actual building layout.

*2 - Shared workstation.

SECTION C. FOOTPRINT GUIDELINES FOR INDIVIDUAL SPACES

Work spaces designed for the task and function of an individual's job has been found to be more efficient. The typical 8' x 8' footprint (64 square feet) is the standard workspace size for the majority of staff functions and offers the greatest flexibility and benefit. Smaller (6' x 6' and 6' x 8') and larger (8' x 12' and 10' x 12') footprints have also been included. The smaller standard may be used for individuals whose task and functions determine the smaller area, such as part-time, telecommuting and data entry functions. The larger footprints may be used for individuals whose task and functions necessitate larger meeting areas or require special consideration for large documents or special equipment within their space.

The suggested Work Space Standards are intended as a planning guide for the State of Missouri offices when new office space is needed or when modifying existing space. It should assist state divisions in designing new office layouts. They are *guidelines* and depend on existing conditions. The following standards are a visual reference to illustrate square footages. Details of panel height and componentry will be determined on a case by case basis. The footprint layouts are enclosed in this section.

The following criteria helped determine functional issues for individual footprints: paperwork/task, computer/equipment, work surface use, filing/reference and privacy needs, all measured by high, moderate or low usage. Conferencing was measured by either answering yes with the number of users, or no.

Position titles and job codes, along with grade level are enclosed in **Section B** of this document that defines an acceptable footprint. Refer to <http://www.oe.mo.gov/fmdc/> under the **State Agency Information** section to access the most current Statewide Space Standards Manual reflecting monthly class title modifications.

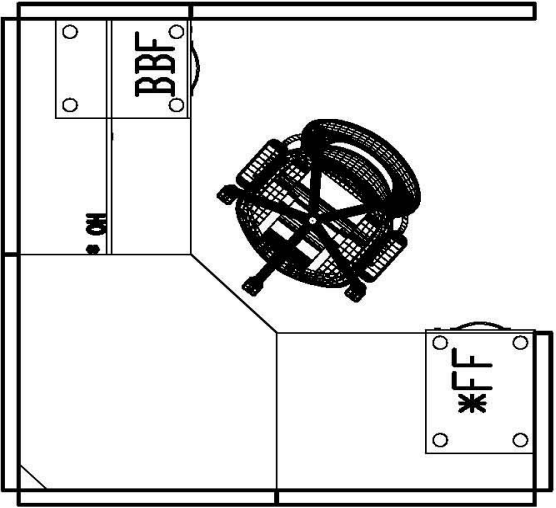
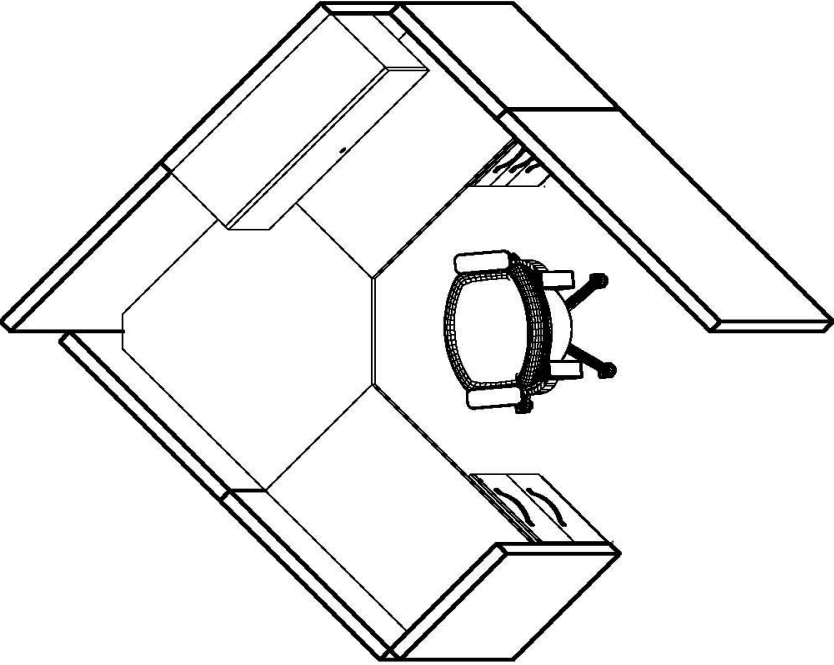
| | | | |
|---|--|---|--|
| <p>WKSTN-0-0036</p> |  | <p>*NOTE: ONE ADDITIONAL FILE CABINET MAY BE ADDED AS NEEDED. *NOTE: ONE OVERHEAD COMPARTMENT MAY BE ADDED AS NEEDED.</p> | <p>6x6 TYPICAL 36 SQ FT DATE: 03-24-06</p> |
|  | <p>FUNCTIONAL ASSIGNMENT: THIS IS A STANDARD WORKSPACE SIZE FOR ALL PART-TIME NON-SUPERVISORY FUNCTIONS THAT REQUIRE SPECIAL CONSIDERATION FOR THE FOLLOWING: PAPERWORK/TASK: MODERATE COMPUTER/EQUIPMENT USE: LOW WORKSURFACE USE: LOW FILING/REFERENCE: LOW CONFERENCING: NONE PRIVACY - VISUAL/ACOUSTICAL: LOW</p> | <p>STATE OF MISSOURI STATEWIDE SPACE STANDARDS</p> | |

WKSTN-0-0048

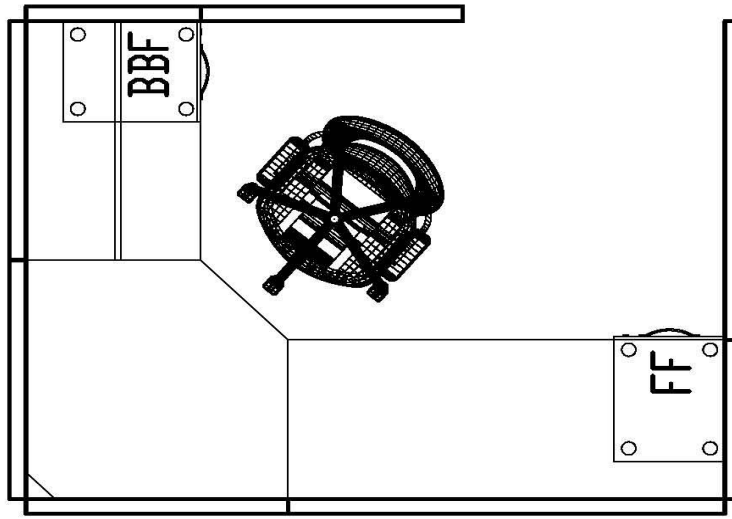
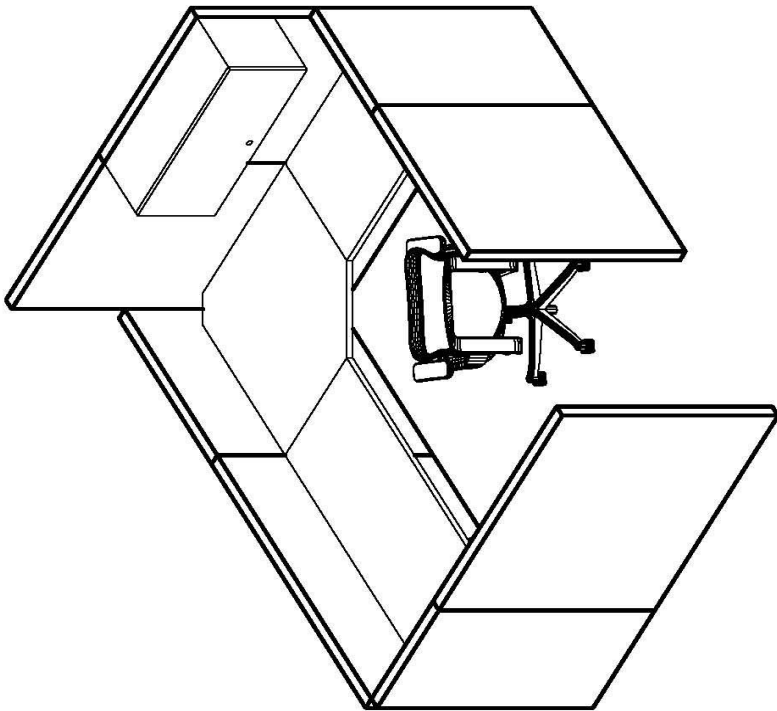

FUNCTIONAL ASSIGNMENT:
THIS IS A STANDARD WORKSPACE SIZE FOR NON-SUPERVISORY
FUNCTIONS THAT REQUIRE SPECIAL CONSIDERATION
FOR THE FOLLOWING:
PAPERWORK/TASK: MODERATE
COMPUTER/EQUIPMENT USE: MODERATE
WORKSURFACE USE: MODERATE
FILING/REFERENCE: MODERATE
CONFERENCING: NONE
PRIVACY - VISUAL /ACOUSTICAL: LOW

6X8 TYPICAL
48 SQ FT
DATE
03-24-06

STATE OF MISSOURI

STATEWIDE SPACE STANDARDS

WKSTN-0-0064A

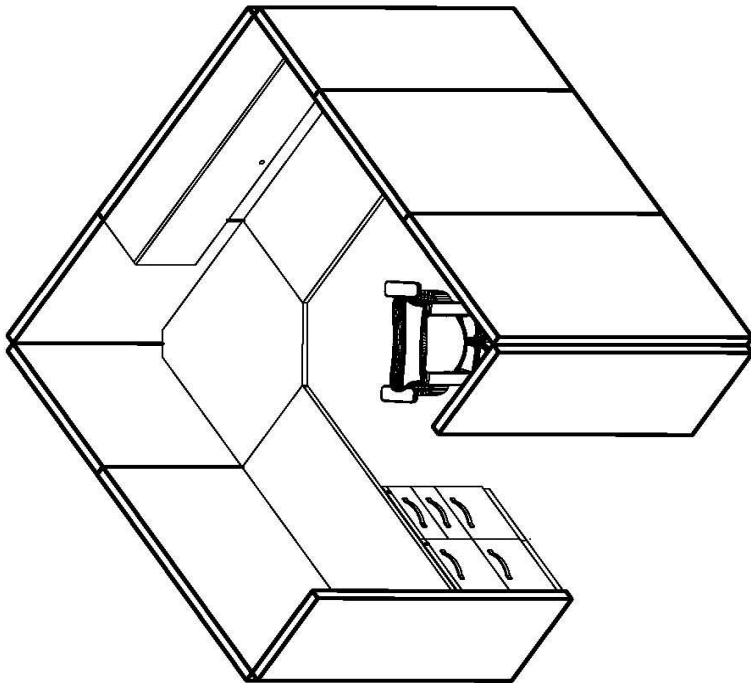
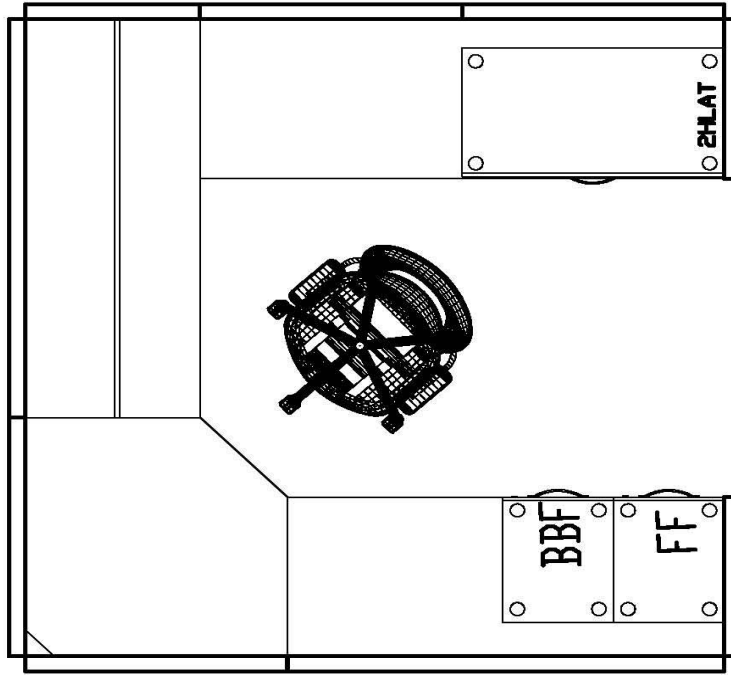

FUNCTIONAL ASSIGNMENT:
 THIS IS A STANDARD WORKSPACE SIZE FOR SEMI-SUPERVISORY
 FUNCTIONS THAT REQUIRE SPECIAL CONSIDERATION FOR THE FOLLOWING:
 PAPERWORK/TASK: MODERATE
 COMPUTER/EQUIPMENT USE: HIGH
 WORKSURFACE USE: HIGH
 FILING/REFERENCE: MODERATE
 CONFERRING: NONE
 PRIVACY - VISUAL/ACOUSTICAL: MODERATE

8X8 "A" TYPICAL

64 SQ FT

DATE
03-24-06

STATE OF MISSOURI

STATEWIDE SPACE STANDARDS

WKSTN-0-0064B

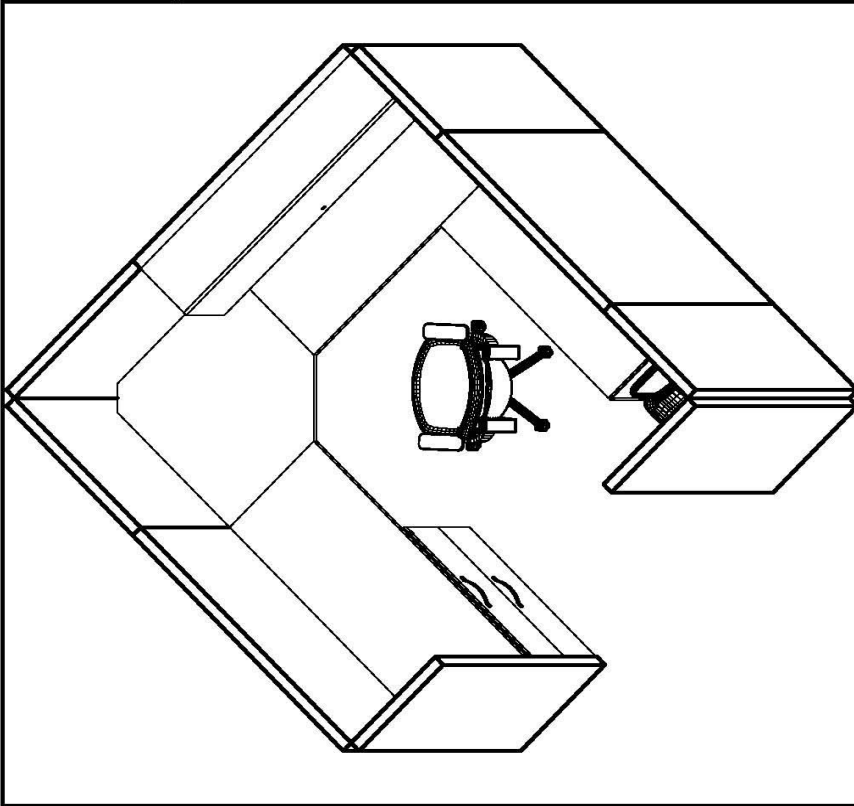
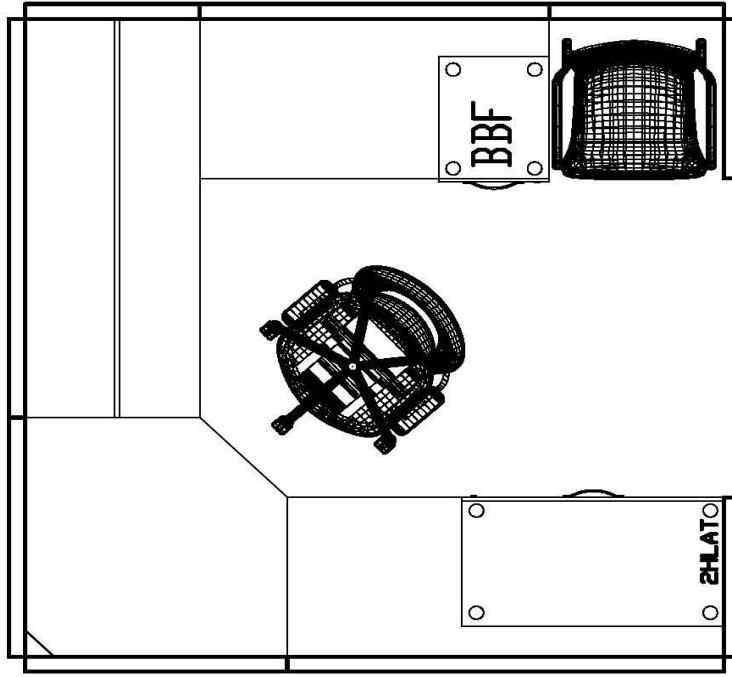

FUNCTIONAL ASSIGNMENT:
 THIS IS A STANDARD WORKSPACE SIZE FOR SEMI-SUPERVISORY
 FUNCTIONS THAT REQUIRE SPECIAL CONSIDERATION FOR THE
 FOLLOWING:
 PAPERWORK/TASK: MODERATE
 COMPUTER/EQUIPMENT USE: MODERATE
 WORKSURFACE USE: HIGH
 FILING/REFERENCE: MODERATE
 CONFERRING: ONE PERSON
 PRIVACY - VISUAL/ ACOUSTICAL: MODERATE

8X8 "B" TYPICAL

64 SQ FT

DATE
03-24-06

STATE OF MISSOURI
 STATEWIDE SPACE STANDARDS

WKSTN-0-0064C

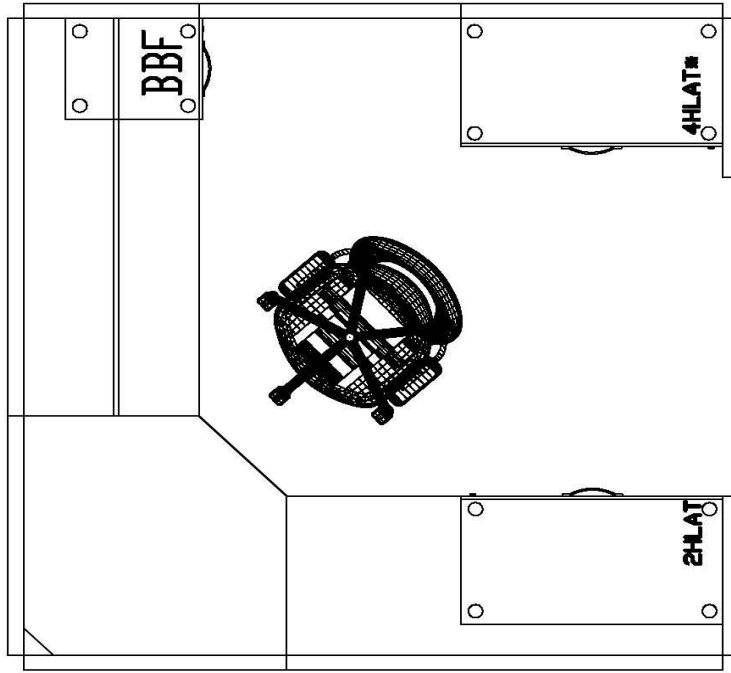

*NOTE: ONE ADDITIONAL FILE CABINET MAY BE ADDED AS NEEDED.

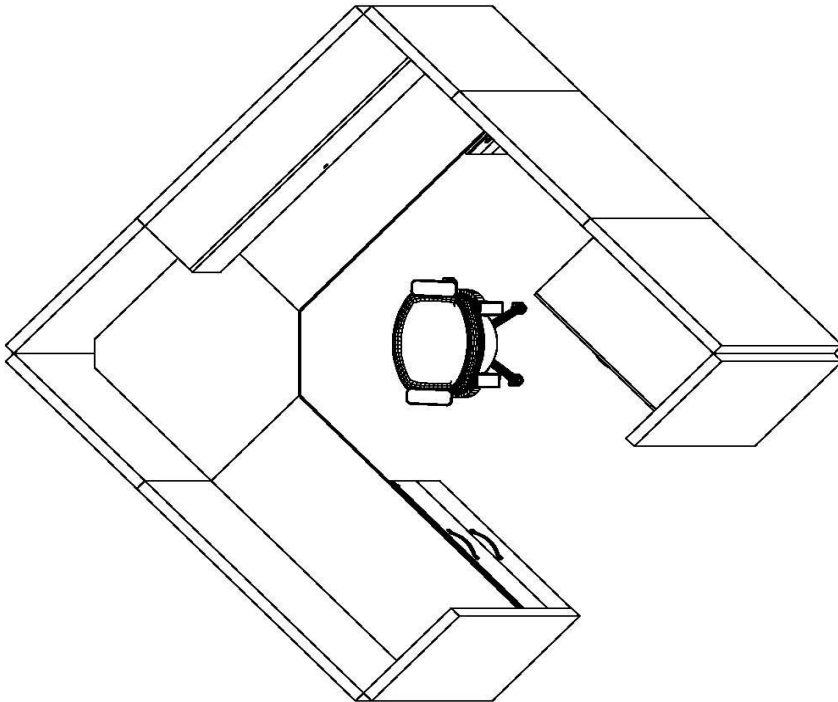

FUNCTIONAL ASSIGNMENT:
 THIS IS A STANDARD WORKSPACE SIZE FOR NON-SUPERVISORY FUNCTIONS
 THAT REQUIRE SPECIAL CONSIDERATION FOR THE FOLLOWING:
 PAPERWORK/TASK: MODERATE
 COMPUTER/EQUIPMENT USE: MODERATE
 WORKSURFACE USE: MODERATE
 FILING/REFERENCE: HIGH
 CONFERRING: NONE
 PRIVACY - VISUAL/ ACOUSTICAL: MODERATE

8X8 "C" TYPICAL

64 SQ FT

DATE
03-24-06

STATE OF MISSOURI

STATEWIDE SPACE STANDARDS

WKSTN-0-0064D

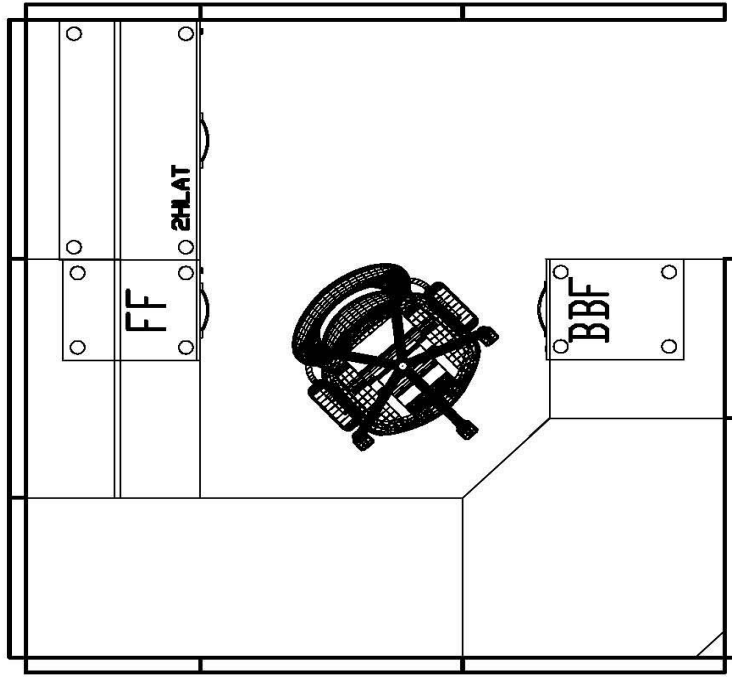

8X8 "D" TYPICAL

64 SQ FT

DATE
03-24-06

STATE OF MISSOURI

STATEWIDE SPACE STANDARDS

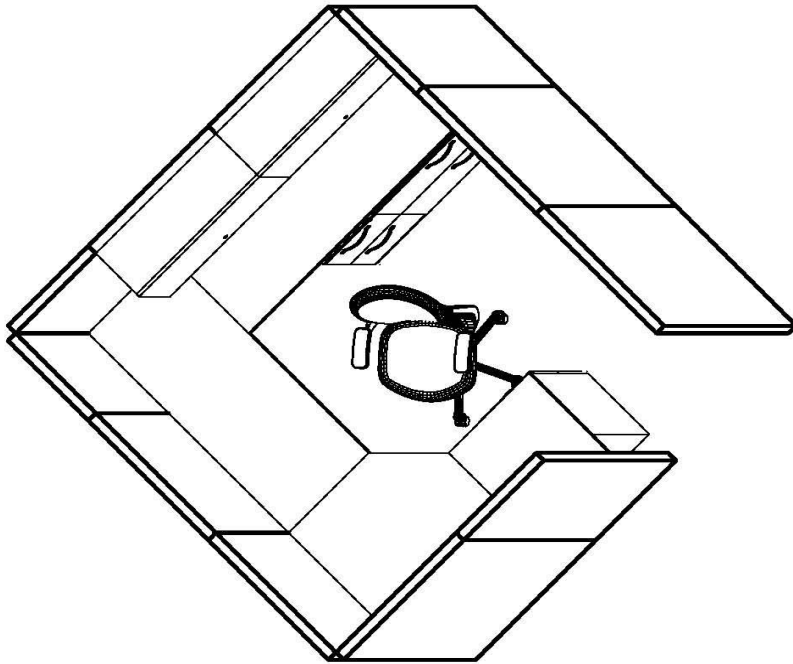

FUNCTIONAL ASSIGNMENT:
 THIS IS A STANDARD WORKSPACE SIZE FOR SEMI-SUPERVISORY
 FUNCTIONS THAT REQUIRE SPECIAL CONSIDERATION FOR THE FOLLOWING:
 PAPERWORK/TASK: MODERATE
 COMPUTER/EQUIPMENT USE: HIGH
 WORKSURFACE USE: HIGH
 FILING/REFERENCE: MODERATE
 CONFERRING: NONE
 PRIVACY - VISUAL/ACOUSTICAL: MODERATE

WKSTN-0-0064E

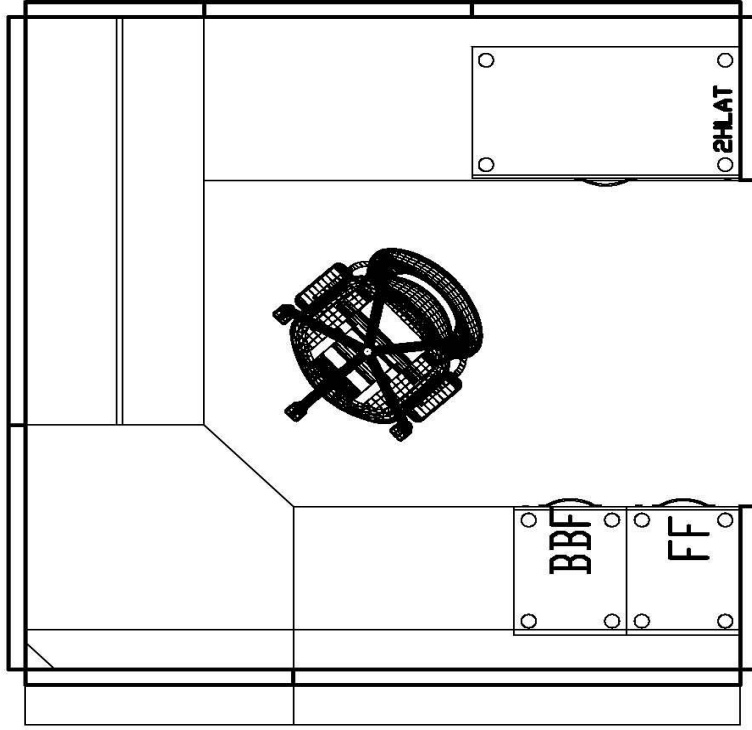
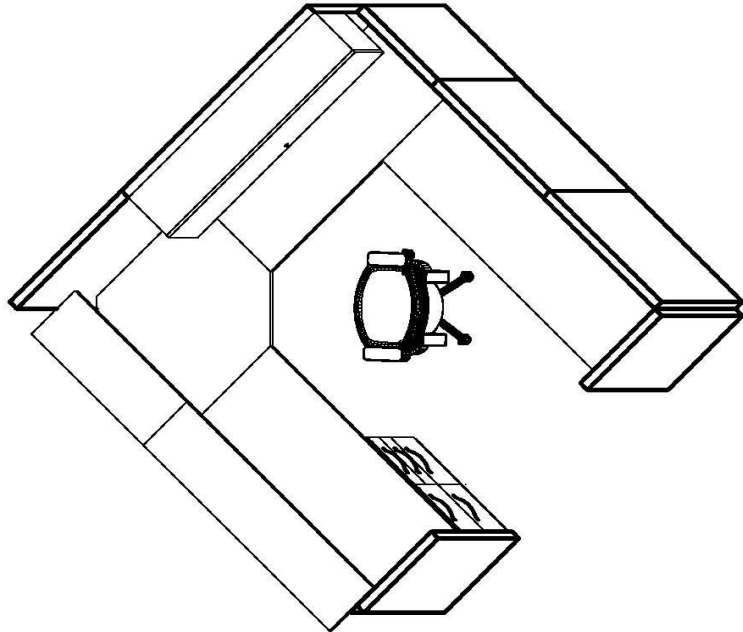

FUNCTIONAL ASSIGNMENT:
 THIS IS A STANDARD WORKSPACE SIZE FOR SEMI-SUPERVISORY
 FUNCTIONS THAT REQUIRE SPECIAL CONSIDERATION FOR THE FOLLOWING:
 PAPERWORK/TASK: MODERATE
 COMPUTER/EQUIPMENT USE: HIGH
 WORKSURFACE USE: HIGH
 FILING/REFERENCE: MODERATE
 CONFERRING: NONE
 PRIVACY - VISUAL/ACOUSTICAL: MODERATE

8X8 "E" TYPICAL

64 SQ FT

DATE
03-24-06

STATE OF MISSOURI
 STATEWIDE SPACE STANDARDS

WKSTN-0-0096A

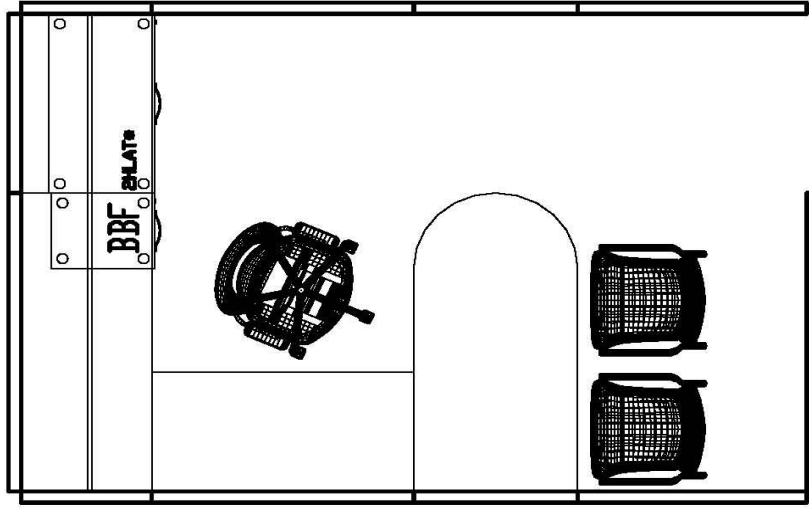

*NOTE: FILING MAY CHANGE AS NEEDED.

8X12 "A" TYPICAL
 96 SQ FT
 DATE 03-24-06

STATE OF MISSOURI
 STATEWIDE SPACE STANDARDS

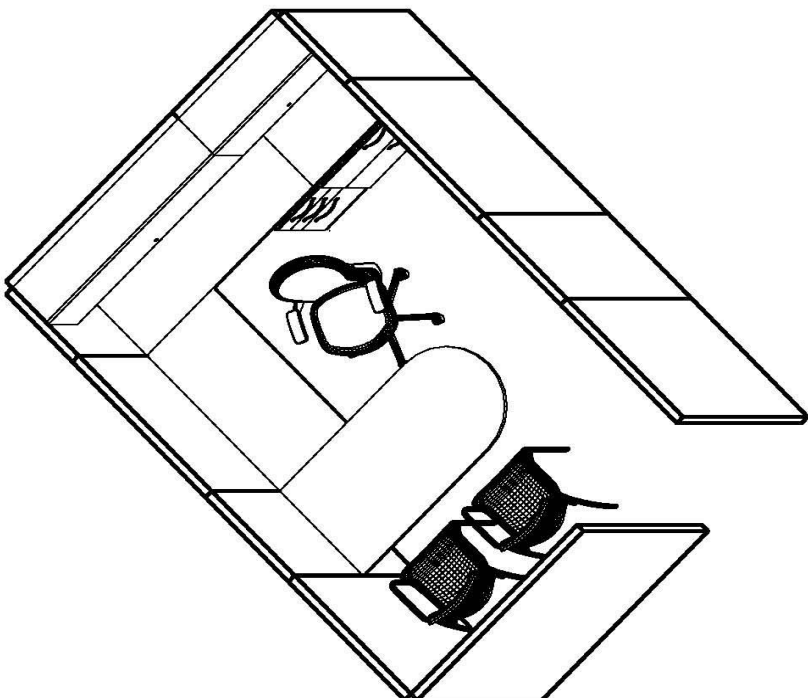

FUNCTIONAL ASSIGNMENT:
 THIS IS A STANDARD WORKSPACE SIZE FOR ALL FRONT LINE SUPERVISOR
 JOB FUNCTIONS AND MANAGERIAL FUNCTIONS THAT REQUIRE
 SPECIAL CONSIDERATION FOR THE FOLLOWING:
 PAPERWORK/TASK: MODERATE
 COMPUTER/EQUIPMENT USE: HIGH
 WORK SURFACE USE: HIGH
 FILING/REFERENCE: MODERATE
 CONFERRING: THREE PEOPLE
 PRIVACY - VISUAL/ACOUSTICAL: MODERATE

WKSTN-0-0096B

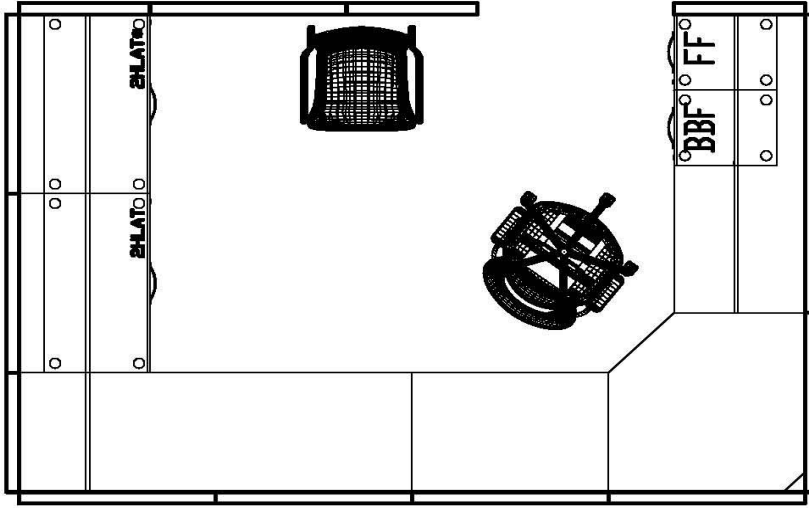

*NOTE: ONE ADDITIONAL TWO DRAWER LATERAL FILE CABINET MAY BE ADDED AS NEEDED.

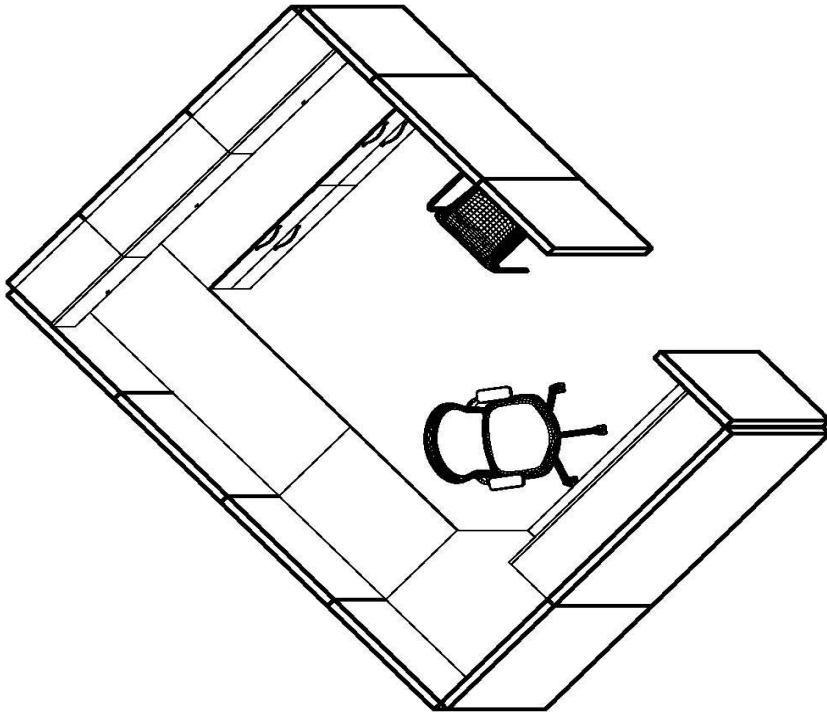

FUNCTIONAL ASSIGNMENT:
 THIS IS A STANDARD WORKSPACE SIZE FOR SEMI-SUPERVISORY
 FUNCTIONS THAT REQUIRE SPECIAL CONSIDERATION FOR THE FOLLOWING:
 PAPERWORK/TASK: HIGH, OVERSIZED DOCUMENTS
 COMPUTER/EQUIPMENT USE: HIGH
 WORKSURFACE USE: HIGH
 FILING/REFERENCE: MODERATE
 CONFERRING: TWO PEOPLE
 PRIVACY - VISUAL/ACOUSTICAL: MODERATE

8X12 "B" TYPICAL

96 SQ FT

DATE
03-24-06

STATE OF MISSOURI

STATEWIDE SPACE STANDARDS

WKSTN-0-0120

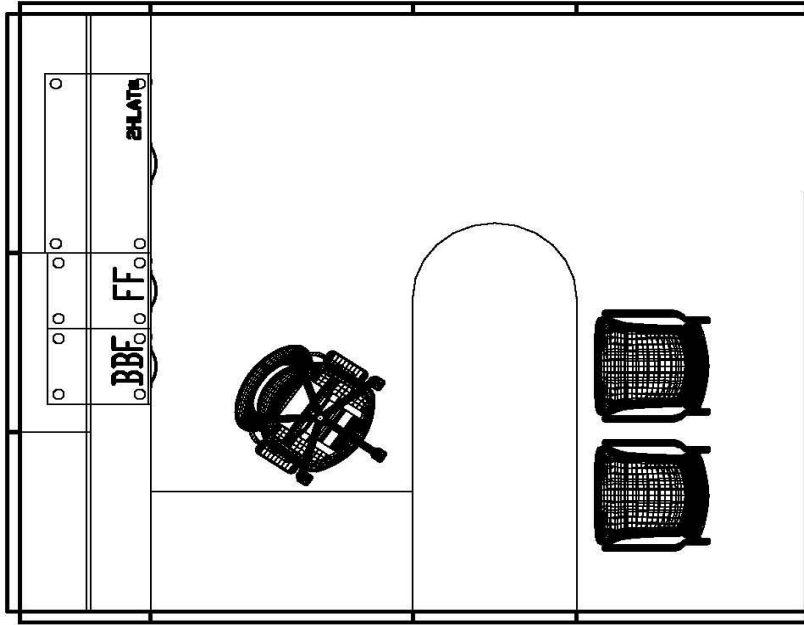

*NOTE: ONE FOUR HIGH LATERAL FILE CABINET MAY BE REPLACED AS NEEDED.

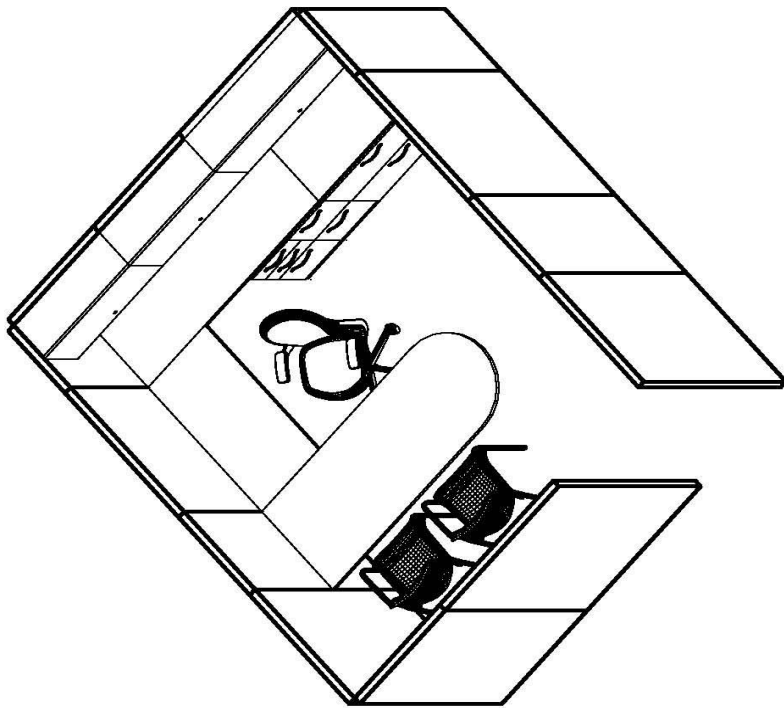

FUNCTIONAL ASSIGNMENT:
 THIS IS A STANDARD WORKSPACE SIZE FOR SOME SUPERVISORY
 JOB FUNCTIONS THAT REQUIRE CONFIDENTIALITY, SECURITY, VISUAL
 AND ACOUSTICAL PRIVACY:
 PAPERWORK/TASK: HIGH
 COMPUTER/EQUIPMENT USE: HIGH
 WORK SURFACE USE: HIGH
 FILING/REFERENCE: HIGH
 CONFERRING: THREE PLUS
 PRIVACY - VISUAL/ACOUSTICAL: MODERATE

10X12 TYPICAL
 120 SQ FT
 DATE
 03-24-06

STATE OF MISSOURI
 STATEWIDE SPACE STANDARDS

OFFICE - P-0120

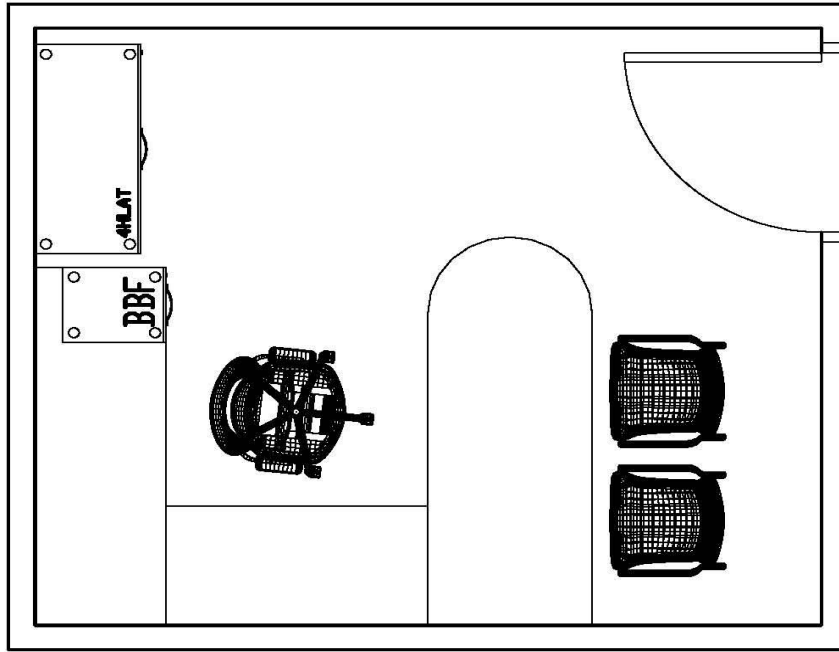

10X12 OFFICE TYPICAL

120 SQ FT

DATE
03-24-06

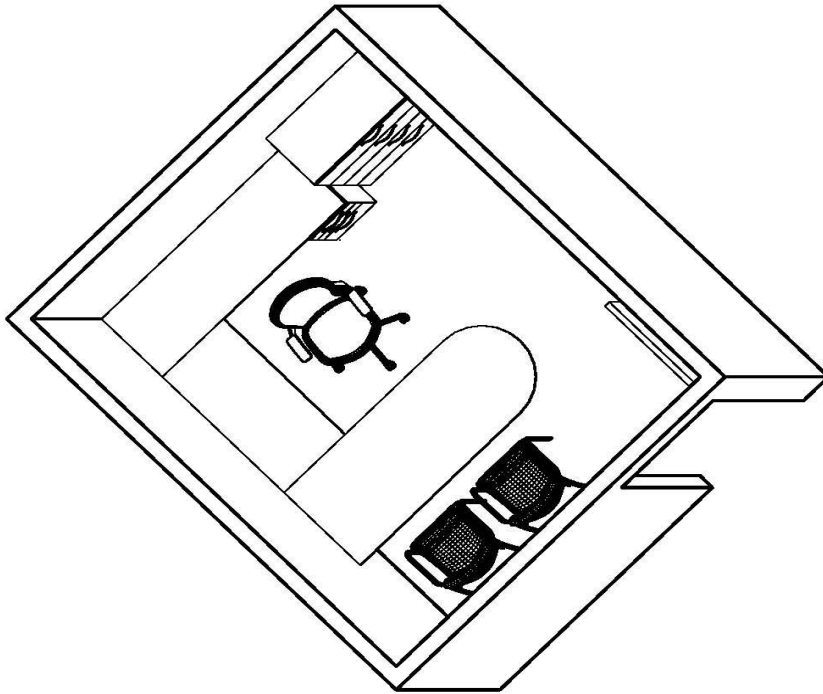

FUNCTIONAL ASSIGNMENT:
 THIS IS A STANDARD WORKSPACE SIZE FOR SOME SUPERVISORY JOB
 FUNCTIONS THAT REQUIRE CONFIDENTIALITY, SECURITY,
 VISUAL AND ACOUSTICAL PRIVACY:
 PAPERWORK/TASK: HIGH
 COMPUTER/EQUIPMENT USE: MODERATE
 WORK SURFACE USE: MODERATE
 FILING/REFERENCE: HIGH
 CONFERRING: THREE PLUS
 PRIVACY - VISUAL/ACOUSTICAL: HIGH

STATE OF MISSOURI

STATEWIDE SPACE STANDARDS

OFFICE--P--0240

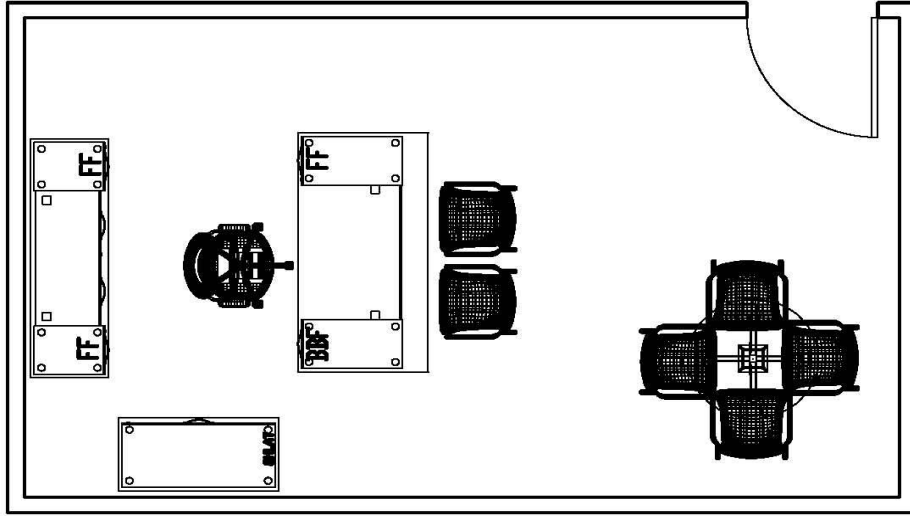
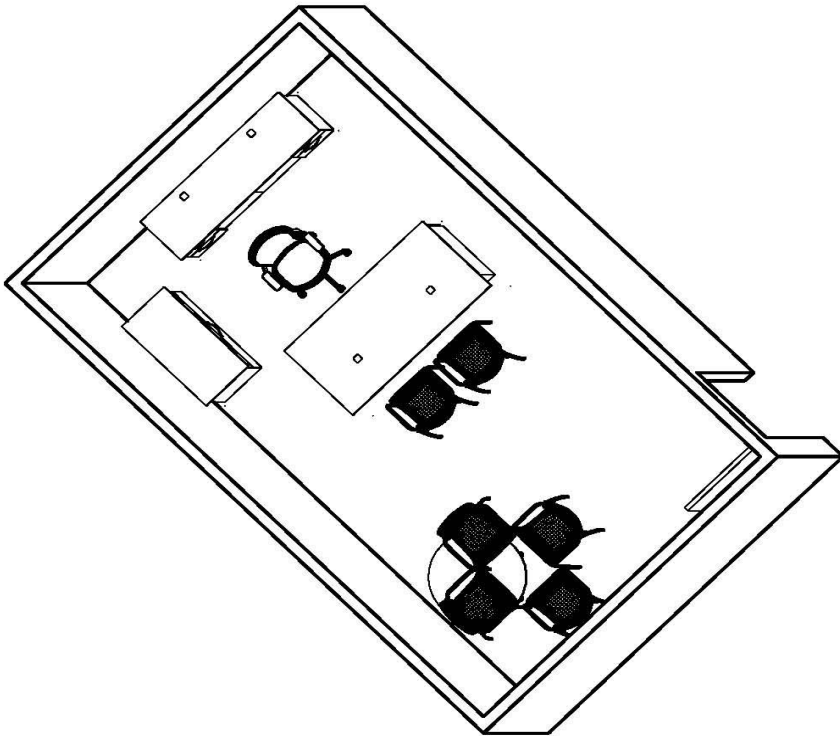

FUNCTIONAL ASSIGNMENT:
 THIS IS A STANDARD WORKSPACE SIZE FOR CERTAIN JOB FUNCTIONS THAT REQUIRE CONFIDENTIALITY, SECURITY, VISUAL AND ACOUSTICAL PRIVACY:
 PAPERWORK/TASK: MODERATE
 COMPUTER/EQUIPMENT USE: MODERATE
 WORK SURFACE USE: MODERATE
 FILING/REFERENCE: MODERATE
 CONFERENCING: FOUR PLUS
 PRIVACY - VISUAL/ACOUSTICAL: HIGH

12X20 OFFICE TYPICAL

240 SQ FT

DATE
03-24-06

STATE OF MISSOURI

STATEWIDE SPACE STANDARDS

SECTION D. GUIDELINES FOR FUNCTIONAL SUPPORT AREAS

Space for areas other than individual work areas are listed in this section. Space has been determined both by examining current State of Missouri functional support standards and by using specialized industry standards.

Within this section, the Room Standard Codes that are listed for each space is made up of three categories. For example, with CONF-P-0240, CONF describes the function of the room (Conference); P identifies private (drywall) or O identifies open; and 0240 defines the square feet allocated for the room (240 square feet).

If a functional need is required outside the standard listing, please document the information in the comments section of the Space Analysis in the Functional Support Area details.

FUNCTIONAL SUPPORT AREA SPACE STANDARDS

**OFFICE OF ADMINISTRATION
DIVISION OF FACILITIES MANAGEMENT
OFFICE & SUPPORT AREA CODES**

| FUNCTIONAL TYPE | ROOM STANDARD | STANDARD DESCRIPTION | ALLOCATED AREA | CAPACITY |
|-----------------|---------------------|--|----------------|----------|
| Common Core | ELEVATOR-0200 | Elevator | 200 | |
| Common Core | JANITOR-P-0048 | Janitor's Closet | 48 | |
| Common Core | RESTROOM-CF-0060 | Client Rest Room - Female - 1 Person Capacity | 60 | 1 |
| Common Core | RESTROOM-CM-0060 | Client Rest Room - Male - 1 Person Capacity | 60 | 1 |
| Common Core | RESTROOM-CU-0060 | Client Rest Room - Unisex - 1 Person Capacity | 60 | 1 |
| Common Core | RESTROOM-F-0060 | Restroom Facility - Female - 1 Person Capacity | 60 | 1 |
| Common Core | RESTROOM-F-0150 | Restroom Facility - Female - 2 Person Capacity | 150 | 2 |
| Common Core | RESTROOM-F-0180 | Restroom Facility - Female - 3 Person Capacity | 180 | 3 |
| Common Core | RESTROOM-F-0220 | Restroom Facility - Female - 4 Person Capacity | 220 | 4 |
| Common Core | RESTROOM-F-0260 | Restroom Facility - Female - 5 Person Capacity | 260 | 5 |
| Common Core | RESTROOM-F-0300 | Restroom Facility - Female - 6 Person Capacity | 300 | 6 |
| Common Core | RESTROOM-M-0060 | Restroom Facility - Male - 1 Person Capacity | 60 | 1 |
| Common Core | RESTROOM-M-0150 | Restroom Facility - Male - 2 Person Capacity | 150 | 2 |
| Common Core | RESTROOM-M-0180 | Restroom Facility - Male - 3 Person Capacity | 180 | 3 |
| Common Core | RESTROOM-M-0220 | Restroom Facility - Male - 4 Person Capacity | 220 | 4 |
| Common Core | RESTROOM-U-0060 | Restroom Facility - Unisex - 1 Person Capacity | 60 | 1 |
| Common Core | SHOWER-F-0150 | Shower Facility - Female | 150 | |
| Common Core | SHOWER-M-0150 | Shower Facility - Male | 150 | |
| Equipment | EQUIP-O-0006 | Desktop Printer | 6 | |
| Equipment | EQUIP-O-0018 | Microfiche Viewer/Cabinet | 18 | |
| Equipment | EQUIP-O-0020 | Small Freestanding Copier / Printer | 20 | |
| Equipment | EQUIP-O-0030 | Postage/Shredder | 30 | |
| Equipment | EQUIP-O-0032 | Microfiche Machine 4' x 5' | 32 | |
| Equipment | EQUIP-O-0040 | Medium Freestanding Copier / Printer | 40 | |
| Equipment | EQUIP-O-0050 | Miscellaneous Equipment | 50 | |
| Equipment | EQUIP-O-0060 | Large Freestanding Copier / Printer | 60 | |
| Equipment | EQUIP-P-0120 | Equipment Room | 120 | |
| Furniture | BOOKCASE-O-0006 | Bookcase - 36w | 6 | |
| Furniture | BOOKCASE-O-0008 | Bookcase - 48w | 8 | |
| Furniture | CHAIR-O-0012 | Guest Chair | 12 | |
| Furniture | FILEFLAT-O-0024 | Flat File Cabinet (48x36) | 24 | |
| Furniture | FILEFLAT-O-0040 | Flat File Cabinet (60x48) | 40 | |
| Furniture | FILEHANGPLAN-O-0012 | Hanging Plan File (18x30) | 12 | |
| Furniture | FILEHANGPLAN-O-0028 | Hanging Plan File (24x42) | 28 | |
| Furniture | FILEHIGHDENS-O-0040 | High Density File Unit | 40 | |
| Furniture | FILELATERAL-O-0009 | Lateral File Cabinet - 36w | 9 | |
| Furniture | FILELATERAL-O-0011 | Lateral File Cabinet - 42w | 11 | |
| Furniture | FILEPEDESTAL-O-0010 | Pedestal File Cabinet | 10 | |
| Furniture | FILEVERTICAL-O-0009 | Vertical File Cabinet | 9 | |
| Furniture | STORAGECAB-O-0009 | Storage Cabinet - 36w | 9 | |
| Furniture | STORAGECAB-O-0014 | Storage Cabinet - 48w | 14 | |
| Furniture | TABLE-O-0020 | Table - 24x48 | 20 | |
| Furniture | TABLE-O-0028 | Table - 30x60 | 28 | |
| Furniture | TABLE-O-0030 | Table - 36" Round | 30 | |
| Furniture | TABLE-O-0036 | Table - 36x72 | 36 | |
| Furniture | TABLE-O-0038 | Table - 30x84 | 38 | |
| Furniture | TABLEDRAFT-O-0042 | Drafting Table - 48x72 | 42 | |
| Meeting Space | AUD-P-02500 | Auditorium-Small - Seats 175 to 350 | 2,500 | 350 |
| Meeting Space | AUD-P-06000 | Auditorium-Medium - Seats 351 to 800 | 6,000 | 800 |
| Meeting Space | AUD-P-11500 | Auditorium-Large - Seats 801 to 1600 | 11,500 | 1,600 |
| Meeting Space | CONF-P-0120 | Conference Rm - Seats 4 to 6 | 120 | 6 |
| Meeting Space | CONF-P-0240 | Conference Rm - Seats 7 to 10 | 240 | 10 |
| Meeting Space | CONF-P-0360 | Conference Rm - Seats 11 to 18 | 360 | 18 |
| Meeting Space | CONF-P-0480 | Conference Rm - Seats 19 to 25 | 480 | 25 |
| Meeting Space | CONF-P-0840 | Conference Rm - Seats 26 to 34 | 840 | 34 |

| FUNCTIONAL TYPE | ROOM STANDARD | STANDARD DESCRIPTION | ALLOCATED AREA | CAPACITY |
|---------------------|-------------------|--|------------------|----------|
| Meeting Space | CONF-P-1200 | Conference Rm - Seats 35 to 46 | 1,200 | 46 |
| Meeting Space | CONF-P-1665 | Conference Rm - 1,665 SF (Written Justification) | 1,665 | |
| Meeting Space | CONF-P-3000 | Conference Rm - 3,000 SF (Written Justification) | 3,000 | |
| Meeting Space | FAMILY-P-0120 | Family Room | 120 | |
| Meeting Space | HEARING-P-0120 | Hearing Room | 120 | |
| Meeting Space | INTERVIEW-O-0054 | Interview Booth - 2 to 3 Person Capacity | 54 | 3 |
| Meeting Space | INTERVIEW-P-0080 | Interview Room - 4 Person Capacity | 80 | 4 |
| Meeting Space | OBSERV-P-0048 | Observation Room | 48 | |
| Meeting Space | TESTING-P-0120 | Testing Room | 120 | |
| Meeting Space | TRAINING-P-0240 | Training Room - Seats 8 to 10 | 240 | 10 |
| Meeting Space | TRAINING-P-0480 | Training Room - Seats 11 to 19 | 480 | 19 |
| Meeting Space | TRAINING-P-0720 | Training Room - Seats 20 to 31 | 720 | 31 |
| Miscellaneous Areas | BREAK-P-0120 | Break Room - Facilities with 1 to 20 People | 120 | 20 |
| Miscellaneous Areas | BREAK-P-0240 | Break Room - Facilities with 21 to 50 People | 240 | 50 |
| Miscellaneous Areas | COFFEE-O-0060 | Coffee Bar | 60 | |
| Miscellaneous Areas | COPY-P-0120 | Copy Room | 120 | |
| Miscellaneous Areas | DATA COMM-P-0064 | Data / Telecommunications Room - Small | 64 | |
| Miscellaneous Areas | DATA COMM-P-0080 | Data / Telecommunications Room - Medium | 80 | |
| Miscellaneous Areas | DATA COMM-P-0100 | Data / Telecommunications Room - Large | 100 | |
| Miscellaneous Areas | FILE-P-0120 | File Room | 120 | |
| Miscellaneous Areas | FILE-P-0240 | File Room | 240 | |
| Miscellaneous Areas | MAIL-P-0120 | Mail Room | 120 | |
| Miscellaneous Areas | MAIL COPY-P-0120 | Mail / Copy Room | 120 | |
| Miscellaneous Areas | PANTRY-P-0080 | Pantry | 80 | |
| Miscellaneous Areas | PLAY-P-0120 | Play Room | 120 | |
| Miscellaneous Areas | RECEPTION-P-0080 | Reception Area - Seats 1 to 4 | 80 | 4 |
| Miscellaneous Areas | RECEPTION-P-0120 | Reception Area - Seats 5 to 7 | 120 | 7 |
| Miscellaneous Areas | RECEPTION-P-0240 | Reception Area - Seats 8 to 13 | 240 | 13 |
| Miscellaneous Areas | RECEPTION-P-0320 | Reception Area - Seats 14 to 21 | 320 | 21 |
| Miscellaneous Areas | RECEPTION-P-0400 | Reception Area - Seats 22 to 27 | 400 | 27 |
| Miscellaneous Areas | RESOURCE-O-0120 | Resource Area / Library | 120 | |
| Miscellaneous Areas | RESOURCE-P-0120 | Resource Room / Library | 120 | |
| Miscellaneous Areas | SERVER-P-120 | Server Room - Small | 120 | |
| Miscellaneous Areas | SERVER-P-240 | Server Room - Medium | 240 | |
| Miscellaneous Areas | SERVER-P-360 | Server Room - Large | 360 | |
| Miscellaneous Areas | STORAGE-P-0120 | Storage Room | 120 ¹ | |
| Miscellaneous Areas | STORAGE-P-0240 | Storage Room | 240 ¹ | |
| Specialty Areas | ARMORY-P-0060 | Armory | 60 | |
| Specialty Areas | COMP-P-0120 | Computer / Testing | 120 | |
| Specialty Areas | DARK-P-0060 | Dark Room | 60 | |
| Specialty Areas | DAYCARE-P-0120 | Daycare Room | 120 | |
| Specialty Areas | DINING-P-0480 | Dining Room | 480 | |
| Specialty Areas | DORM-P-0100 | Dormitory (Sleeping Quarters Only) | 100 ³ | |
| Specialty Areas | EVIDENCE LKR-0080 | Evidence Locker Room | 80 | |
| Specialty Areas | EVIDENCE-P-0120 | Evidence Room | 120 | |
| Specialty Areas | EXAM-P-0080 | Exam Room | 80 | |
| Specialty Areas | EXAM-P-0120 | Exam Room | 120 | |
| Specialty Areas | EXERCISE-P-0500 | Exercise Room | 500 | |
| Specialty Areas | FEE-P-0240 | Fee Room | 240 | |
| Specialty Areas | GARAGE-P-0840 | Garage | 840 | |
| Specialty Areas | GRAPHICS-P-0120 | Graphics Room | 120 | |
| Specialty Areas | GUARD-O-0096 | Guard Station | 96 | |
| Specialty Areas | HOLDING-P-0120 | Child Holding Area | 120 | |
| Specialty Areas | IMAGING-P-0240 | Imaging/File Room | 240 | |
| Specialty Areas | LAB-P-0200 | Laboratory | 200 | |
| Specialty Areas | LAUNDRY-P-0100 | Laundry | 100 | |
| Specialty Areas | LAYOUT-O-0036 | Layout Area - Small | 36 | |
| Specialty Areas | LAYOUT-O-0064 | Layout Area - Medium | 64 | |
| Specialty Areas | LAYOUT-O-0096 | Layout Area - Large | 96 | |
| Specialty Areas | LOADDOCK-P-0300 | Loading Dock - 1 Bay ² | 300 | |
| Specialty Areas | LOBBY-P-0100 | Building / Floor Lobby Area | 100 | |
| Specialty Areas | MAINT-P-0150 | Maintenance Shop | 150 | |
| Specialty Areas | MECH-P-0150 | Mechanical Room | 150 | |
| Specialty Areas | PRINT-P-1000 | Print Shop | 1,000 | |

| FUNCTIONAL TYPE | ROOM STANDARD | STANDARD DESCRIPTION | ALLOCATED AREA | CAPACITY |
|-----------------|-------------------|-------------------------------|------------------|----------|
| Specialty Areas | SHIP REC-P-0200 | Shipping / Receiving | 200 | |
| Specialty Areas | URINALYSIS-P-0060 | Urinalysis Room | 60 | |
| Specialty Areas | THERAPY-P-0120 | Therapy Room | 120 | |
| Specialty Areas | WAREHOUSE-P-0500 | Warehouse | 500 ¹ | |
| Staffing | OFFICE-P-0120 | Office - 120 Square Feet | 120 | |
| Staffing | OFFICE-P-0240 | Office - 240 Square Feet | 240 | |
| Staffing | WKSTN-O-0036 | Workstation - 36 Square Feet | 36 | |
| Staffing | WKSTN-O-0048 | Workstation - 48 Square Feet | 48 | |
| Staffing | WKSTN-O-0064 | Workstation - 64 Square Feet | 64 | |
| Staffing | WKSTN-O-0096 | Workstation - 96 Square Feet | 96 | |
| Staffing | WKSTN-O-0120 | Workstation - 120 Square Feet | 120 | |

¹ Written justification is needed if requiring a additional square footage.

² Written justification is needed if requiring a loading dock.

³ 100 sf per person. Indicate # of occupants needed.

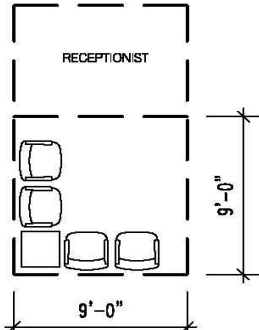

RECEPTION-P-0080
 1-4 SEATING CAPACITY
 80 SF

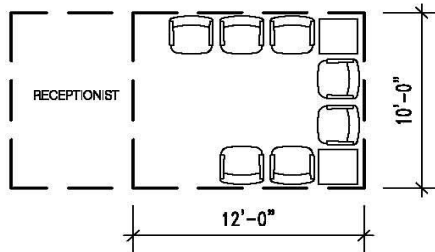

RECEPTION-P-0120
 5-7 SEATING CAPACITY
 120 SF

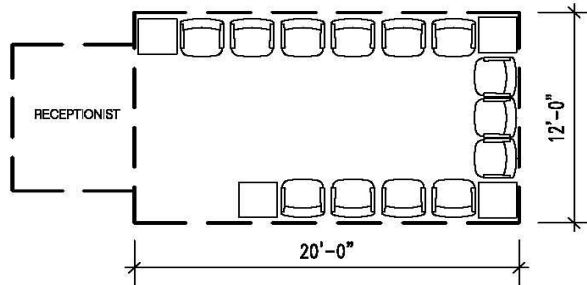

RECEPTION-P-0240
 8-13 SEATING CAPACITY
 240 SF

*NOTE: THE SQUARE FOOTAGE DOES NOT INCLUDE RECEPTIONIST AREA.

STATE OF MISSOURI
 STATEWIDE SPACE STANDARDS

| |
|--------------------|
| SUPPORT SPACE |
| RECEPTION TYPICALS |
| 03-24-06 |

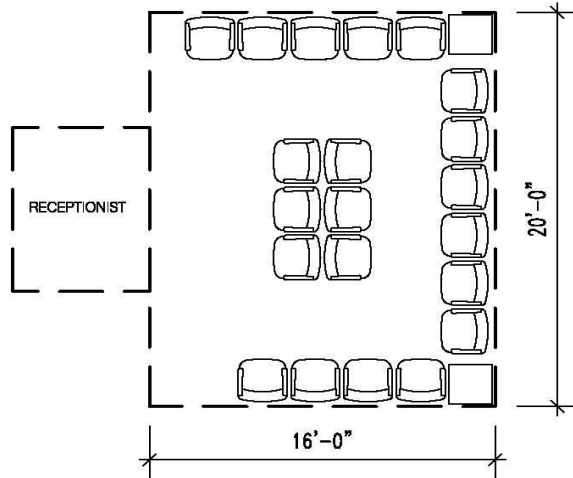

RECEPTION-P-0320
 14-21 SEATING CAPACITY
 320 SF

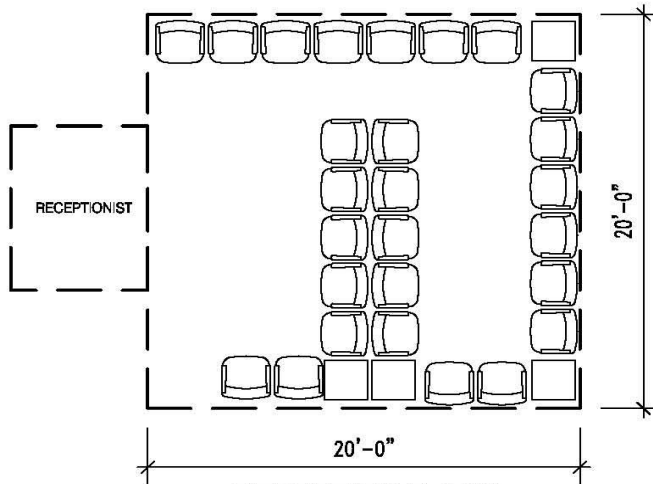

RECEPTION-P-0400
 22-27 SEATING CAPACITY
 400 SF

STATE OF MISSOURI
 STATEWIDE SPACE STANDARDS

SUPPORT SPACE
 RECEPTION TYPICALS
 03-24-06

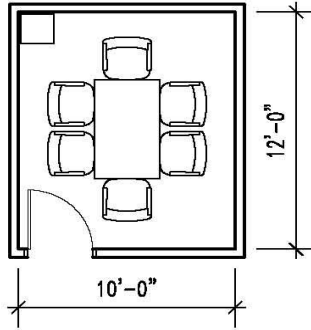

CONF-P-0120
4-6 SEATING CAPACITY
120 SF

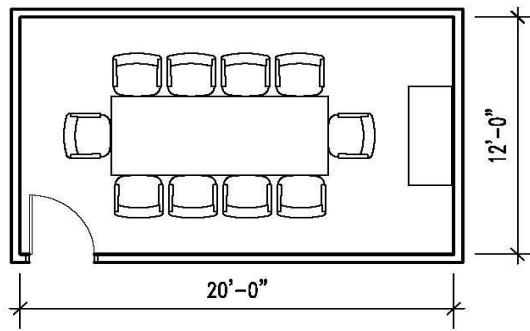

CONF-P-0240
7-10 SEATING CAPACITY
240 SF

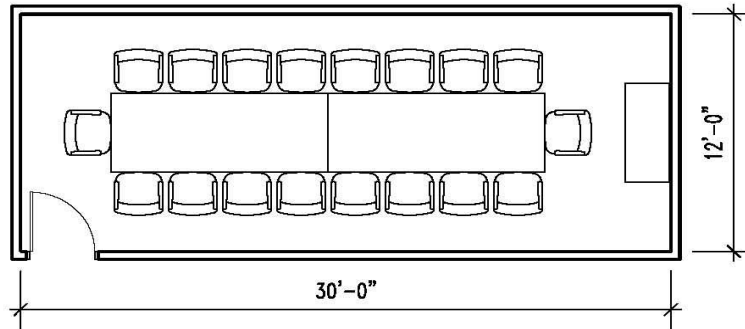

CONF-P-0360
11-18 SEATING CAPACITY
360 SF

STATE OF MISSOURI
STATEWIDE SPACE STANDARDS

SUPPORT SPACE

CONFERENCE TYPICALS

03-24-06

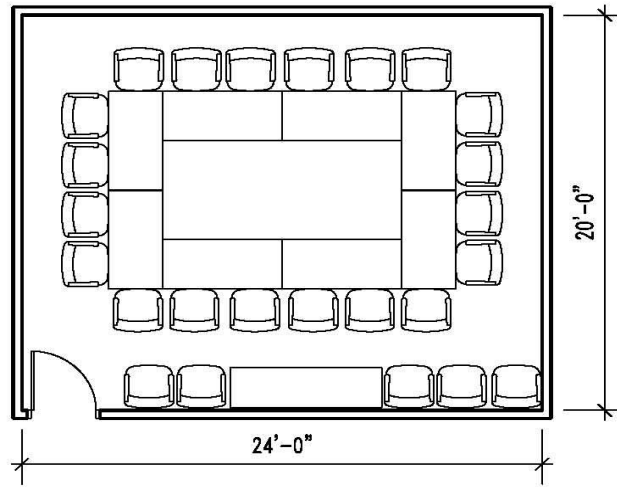

CONF-P-0480
 19-25 SEATING CAPACITY
 480 SF

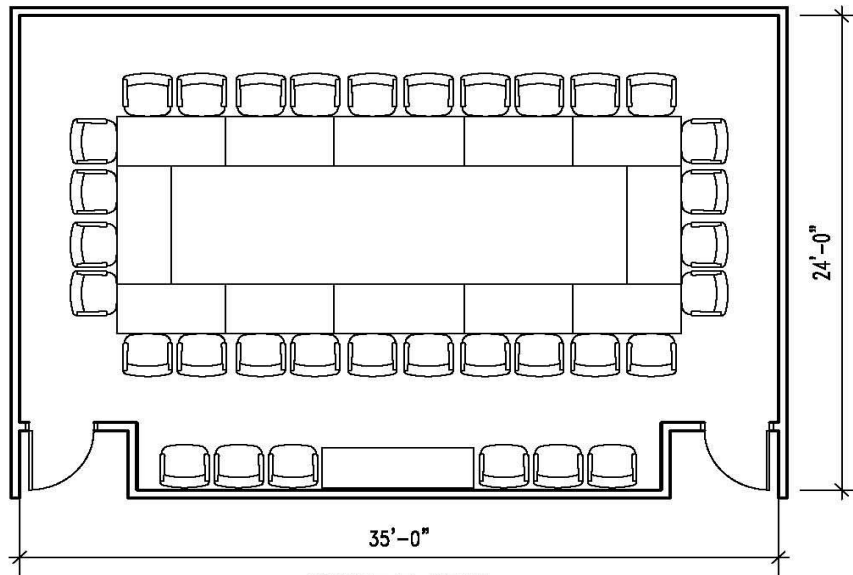

CONF-P-0840
 26-34 SEATING CAPACITY
 840 SF

STATE OF MISSOURI
 STATEWIDE SPACE STANDARDS

SUPPORT SPACE

CONFERENCE TYPICALS

03-24-06

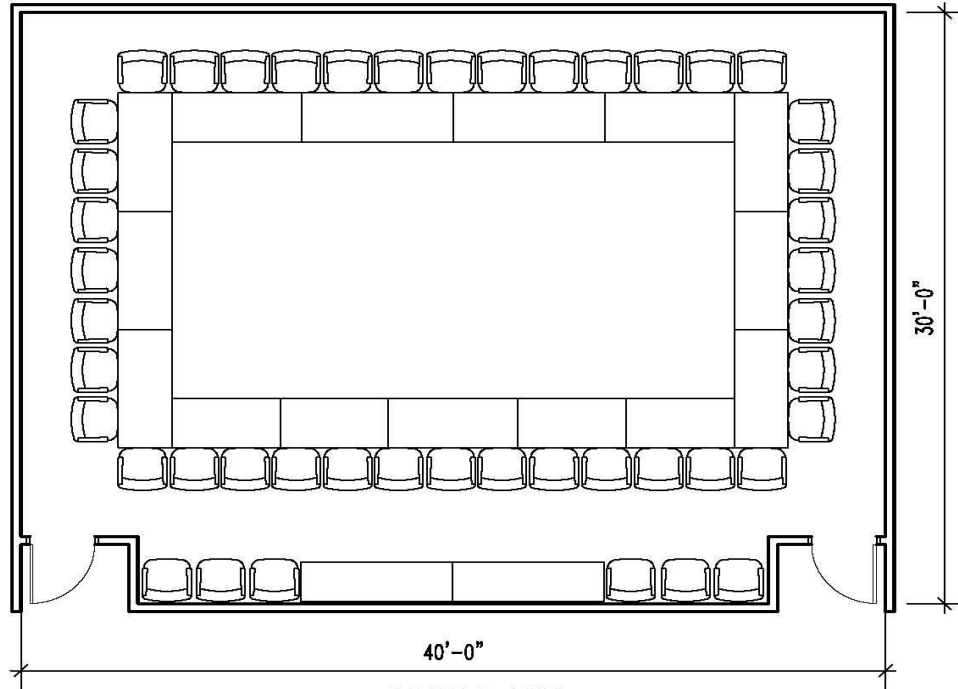

CONF-P-1200
 35-46 SEATING CAPACITY
 1200 SF

STATE OF MISSOURI
 STATEWIDE SPACE STANDARDS

| |
|---------------------|
| SUPPORT SPACE |
| CONFERENCE TYPICALS |
| 03-24-06 |

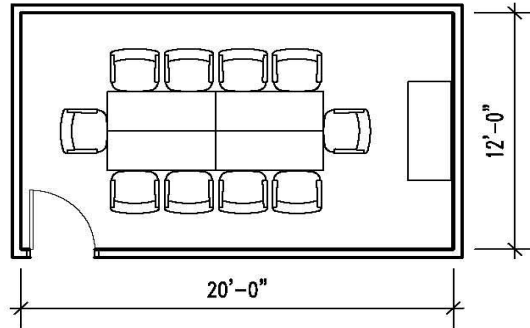

TRAINING-P-0240
 8-10 SEATING CAPACITY
 240 SF

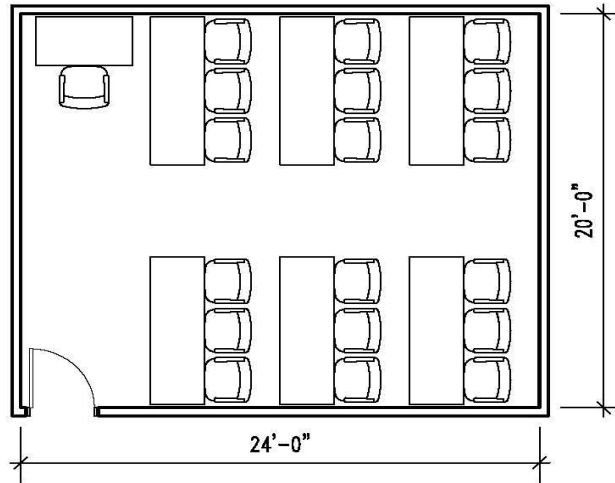

TRAINING-P-0480
 11-19 SEATING CAPACITY
 480 SF

STATE OF MISSOURI
 STATEWIDE SPACE STANDARDS

SUPPORT SPACE
 TRAINING TYPICALS
 03-24-06

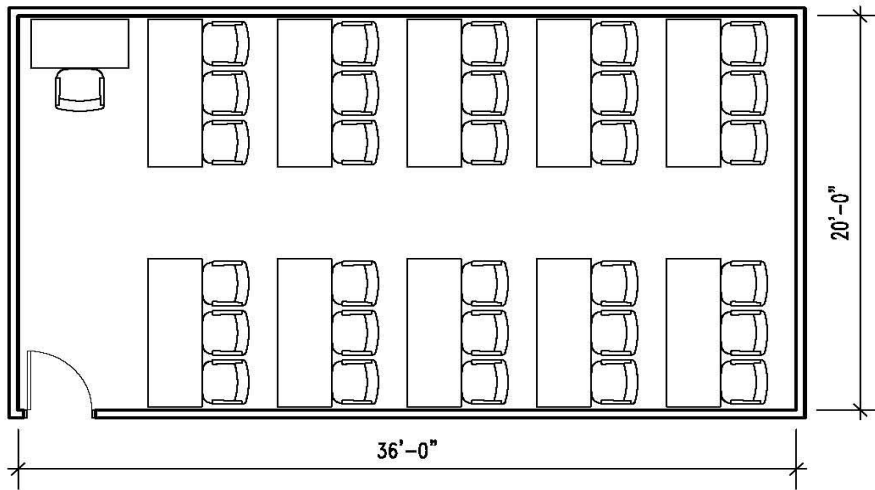

TRAINING-P-0720
 20-31 SEATING CAPACITY
 720 SF

STATE OF MISSOURI
 STATEWIDE SPACE STANDARDS

| |
|-------------------|
| SUPPORT SPACE |
| TRAINING TYPICALS |
| 03-24-06 |

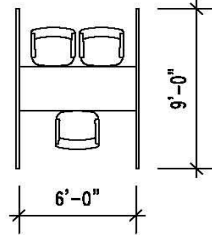

INTERVIEW-O-0054
 2-3 PERSON SEATING CAPACITY
 54 SF

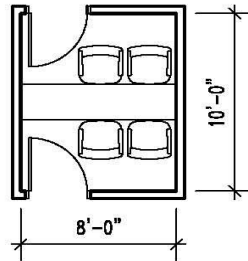

INTERVIEW-P-0080
 INTERVIEW ROOM
 4 PERSON SEATING CAPACITY
 80 SF

RATIO:
 PROBATION & PAROLE: 10 OFFICERS TO 1 INTERVIEW ROOM
 SOCIAL SERVICES: 10 CASE WORKERS TO 1 INTERVIEW ROOM

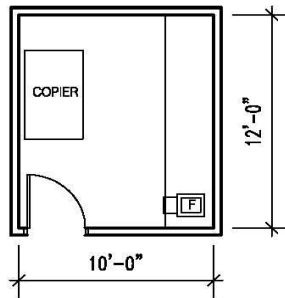

MAIL-P-0120
 MAIL/COPY ROOM
 120 SF

STATE OF MISSOURI
 STATEWIDE SPACE STANDARDS

SUPPORT SPACE

INTERVIEW/MAIL TYPICALS

03-24-06

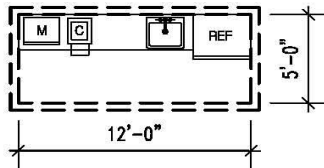

COFFEE-O-0060
 COFFEE BAR
 60 SF

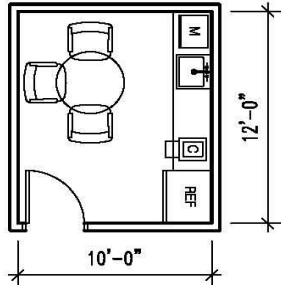

BREAK-P-0120
 1-3 SEATING CAPACITY
 120 SF
 FOR FACILITIES WITH 1 - 20 PEOPLE

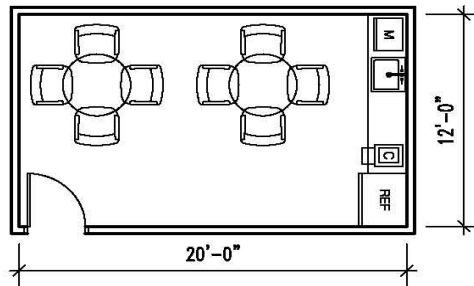

BREAK-P-0240
 4-8 SEATING CAPACITY
 240 SF
 FOR FACILITIES WITH 21 - 50 PEOPLE

TO DETERMINE THE SQUARE FOOTAGE OF BREAKROOMS IN FACILITIES WITH GREATER THAN 50 OCCUPANTS, CALCULATE THE FOLLOWING:
 (TOTAL # OF FTE X 25%) X 20 = SQUARE FOOTAGE OF BREAKROOM
 (ACTUAL SQUARE FOOTAGE MAY VARY BASED ON EXISTING FACILITIES. FINAL SQUARE FOOTAGE TO BE CONFIRMED BY FMDC.)

IF A BUILDING-WIDE CAFETERIA OR BREAKROOM IS AVAILABLE WITHIN A FACILITY, ONLY A COFFEE BAR IS PROVIDED WITHIN DIVISION SPACE.

STATE OF MISSOURI
 STATEWIDE SPACE STANDARDS

SUPPORT SPACE
 BREAKROOM TYPICALS
 04-20-06

Functional Support Areas Space Standards

Interview Booth/Room

| | | |
|------------------|--|----------|
| INTERVIEW-O-0054 | Interview Booth - 2 to 3 Person Capacity | 54 sq ft |
| INTERVIEW-P-0080 | 4 Person Capacity | 80 sq ft |

Conference Room/Auditorium

Conference/Training Room sizes will be determined using the following data:

To determine total square footage allotment, calculate 85% of total # FTE. This will give you the area allotted for a division. For example, a 100 FTE group, $100 \times 85\% = 85$. Per the chart below, 85 equals 1,200 square feet. It is to the division's discretion to determine the breakdown of this total square footage allocation. This could be one 1,200 square foot conference room or five 240 square foot conference rooms, etc. If 85% of your total FTE is greater than 100 people, calculate the total allotment by the following example: 175 FTE's would equal $175 \times 85\% = 149$ people. The total square footage allotted for 149 people would be 1,200 sq ft plus 480 sq ft = 1,680 square feet. It would then be up to the division to determine the breakdown of conference rooms per the square footage allocation.

Conference Room Area Allotment

| | |
|-------------|---------------|
| 120 sq ft | 4-6 People |
| 240 sq ft | 7-10 People |
| 360 sq ft | 11-23 People |
| 480 sq ft | 24-50 People |
| 840 sq ft | 51-75 People |
| 1,200 sq ft | 76-100 People |

Written justification is needed for facilities requiring the following spaces:

Conference Room

| | | |
|-------------|-------------|----------------|
| CONF-P-1665 | 1,665 sq ft | (Seats 47-84) |
| CONF-P-3000 | 3,000 sq ft | (Seats 85-150) |

Auditorium

| | | |
|-------------|--------------|-------------------------|
| AUD-P-02500 | 2,500 sq ft | Small (Seats 175-350) |
| AUD-P-06000 | 6,000 sq ft | Medium (Seats 351-800) |
| AUD-P-11500 | 11,500 sq ft | Large (Seats 801-1,600) |

Circulation Factor

Consolidated Facilities shall include the following Circulation Factors in the Calculations:

30% - Total Departmental Circulation (inclusive of Staffing and Functional Support Area Square Footages)

Data/Telecommunications Room

Data/Telecommunication Rooms shall be calculated with the following formula:

| | |
|--------------------|----------|
| Under 5,000 sq ft | 64 sq ft |
| Under 10,000 sq ft | 80 sq ft |

For every additional 10,000 sq ft, a 100 sq ft data/telecommunications allocation will be provided.

Parking Lot Requirements

Parking is figured with the following formula:

Total #FTE + 25%

The average number of people occupying a facility on a given day is 75% of all FTE. The additional parking provided would account for clients visiting the building. In the event that there is a much larger client load expected, a 40% mark-up would be used in place of 25%. Written justification from the division would be needed before doing such.

Handicapped Parking

| Total Parking in Lot | Required Minimum Number of Accessible Spaces |
|-------------------------|--|
| 1 to 25 | 1 |
| 26 to 50 | 2 |
| 51 to 75 | 3 |
| 76 to 100 | 4 |
| 101 to 150 | 5 |
| 151 to 200 | 6 |
| 201 to 300 | 7 |
| 301 to 400 | 8 |
| 401 to 500 | 9 |
| 501 to 1,000 | 2 percent of total |
| 1,001 and over | 20, plus 1 for each 100 over 1,000 |

***One in every eight accessible spaces, but not less than one, shall be served by an access aisle 96" wide and be designated "van accessible".**

Restroom Requirements

Employee Restrooms

| | <u># of Each Sex</u> | <u># of Closets</u> | <u># of Lavatories</u> | <u>Square Feet</u> |
|----------------------|----------------------|---------------------|------------------------|--------------------|
| <u>Female</u> | | | | |
| RESTROOM-F-0060 | 1-15 | 1 | 1 | 60 |
| RESTROOM-F-0150 | 16-40 | 2 | 1 | 150 |
| RESTROOM-F-0180 | 41-50 | 3 | 2 | 180 |
| RESTROOM-F-0220 | 51-75 | 4 | 2 | 220 |
| RESTROOM-F-0260 | 76-100 | 5 | 3 | 260 |
| RESTROOM-F-0300 | 101-150 | 6 | 3 | 300 |
| <u>Male</u> | | | | |
| RESTROOM-M-0060 | 1-40 | 1 | 1 | 60 |
| RESTROOM-M-0150 | 41-60 | 2 | 1 | 150 |
| RESTROOM-M-0180 | 61-100 | 3 | 2 | 180 |
| RESTROOM-M-0220 | 101-150 | 4 | 2 | 220 |
| <u>Unisex</u> | | | | |
| RESTROOM-U-0060 | 1-15 (RE: Note #3) | 1 | 1 | 60 |

- NOTES:
- The formula to calculate restroom requirements is as follows: Net Gross Sq Ft ÷ 100 = X. Then X ÷ 2 = Y, with Y equaling the number of each sex. For example, a 10,000 sq ft facility = 10,000 ÷ 100 = 100; 100 ÷ 2 = 50. Per the above chart, fifty females equal 3 closets/2 lavatories/180 sq ft and fifty males equal 2 closets/1 lavatory/150 sq ft.
 - Over 150 add one fixture for each additional 80 males and one fixture for each additional 40 females. Lavatories should always to be one-half the number of water closets (round up).
 - Where plumbing fixtures are required, separate facilities shall be provided for each sex, with the exceptions of the following:
 - Separate employee facilities shall not be required in occupancies in which 15 or fewer people are employed.
 - Separate facilities shall not be required in structures or tenant spaces with a total occupant load, including both employees and customers, of 15 or less.

Client Restrooms

| | <u># of Closets</u> | <u># of Lavatories</u> | <u>Square Feet</u> |
|----------------------|---------------------|------------------------|--------------------|
| <u>Unisex</u> | | | |
| RESTROOM-CU-0060 | 1 | 1 | 60 |
| <u>Female</u> | | | |
| RESTROOM-CF-0060 | 1 | 1 | 60 |
| <u>Male</u> | | | |
| RESTROOM-CM-0060 | 1 | 1 | 60 |

NOTE: One unisex client restroom can be provided if total visitor occupancy is less than 15.

E. SPACE ANALYSIS

Please request space through the Facility Request Form and the Functional Space Analysis Form. Both of these are available on our website <http://www.oa.mo.gov/fmdc/> under the **State Agency Information** section, along with the current Statewide Space Standards Manual. The requesting division should determine the required space through the use of this procedure and the State of Missouri Space Standards shown in this manual. They will prepare a list of the approved personnel who will occupy the space, along with functional support requirements. Any unusual circumstances which go beyond the guidelines must be identified and complete justification provided. The FMDC (Facilities Management and Design and Construction) group of the State of Missouri will then assist divisions in designing the requested office layout.

SECTION F – SPACE STANDARD APPEALS PROCESS

The Space Standards contained in this document are intended to provide guidance and uniformity to the space planning process for State of Missouri employees. The Division of Facilities Management, Design and Construction (FDDC) will strive to apply these standards in a fair and equitable manner.

The Director of Planning for FMDC will review and approve all space analysis prior to issuance to the requesting department and ensure that, as closely as possible, such space analyses conform to the Space Standards. Because each space planning issue is unique, disagreements regarding decisions made by FMDC will inevitably be a part of the process from time to time. In recognition of this fact, an appeals process has been established such that, when there is disagreement with the FMDC Director of Planning, agencies may appeal such decisions to the Director of FMDC.

Appeals to the Director of FMDC shall be made in writing by the requesting Department Director or their designated representative. In the event that the appeal is denied by the Director of FMDC, departments may appeal directly to the Commissioner of the Office of Administration. Appeals to the Commissioner shall be made in writing by the requesting Department Director or their designated representative. All decisions regarding appeals by the Commissioner shall be made in writing to the requesting department representative and shall be final.